



Sydney
26 Roger Street
Brookvale, NSW 2100
Ph: 9939 9848

South Coast
136 Industrial Road
Oak Flats, NSW 2529
Ph: 4256 5555

sales@thefireplace.com.au

www.thefireplace.com.au

escea.

GAS FIRE USER GUIDE Australia



EF5000

www.escea.net

630114_1 Userguide AUS

Any service work carried out on this appliance must only be done by a recognised escea technician or authorised personnel.

The data plate for this appliance, containing technical information and specifications, can be found to the right of the control tray, near the base of the fire. To access this, the fascia must be removed.

DO NOT PLACE ARTICLES ON OR AGAINST THIS APPLIANCE.

DO NOT USE OR STORE FLAMMABLE MATERIALS NEAR THIS APPLIANCE.

DO NOT SPRAY AEROSOLS IN THE VICINITY OF THIS APPLIANCE WHILST IT IS IN OPERATION.

IT IS NOT RECOMMENDED TO OPERATE THE FIRE WITH THE FASCIA PANELS REMOVED.

THIS APPLIANCE IS NOT INTENDED FOR USE BY YOUNG CHILDREN OR INFIRM PERSONS UNLESS THEY HAVE BEEN ADEQUATELY SUPERVISED BY A RESPONSIBLE PERSON TO ENSURE THAT THEY CAN USE THE APPLIANCE SAFELY.

YOUNG CHILDREN SHOULD BE SUPERVISED TO ENSURE THAT THEY DO NOT PLAY WITH THE APPLIANCE.

THE APPLIANCE MUST BE INSPECTED BEFORE USE AND AT LEAST ANNUALLY BY AN AUTHORISED TECHNICIAN.

THIS APPLIANCE MUST BE INSTALLED IN ACCORDANCE WITH THE MANUFACTURERS WRITTEN INSTRUCTIONS.

Contents

| | |
|--------------------------------|-------|
| Basic Operation _____ | 1 - 4 |
| Removing the Fascia _____ | 5 |
| Cleaning and Maintenance _____ | 6 |
| Warranty Information _____ | 7 |

Basic Operation

The EF5000 is operated by the switch located on the right hand side outer edge of the fascia. The basic operations possible are ON/OFF. **Before operating the fire, ensure the power transformer is plugged into the mains wall socket & turned on, and the supply is turned on.**

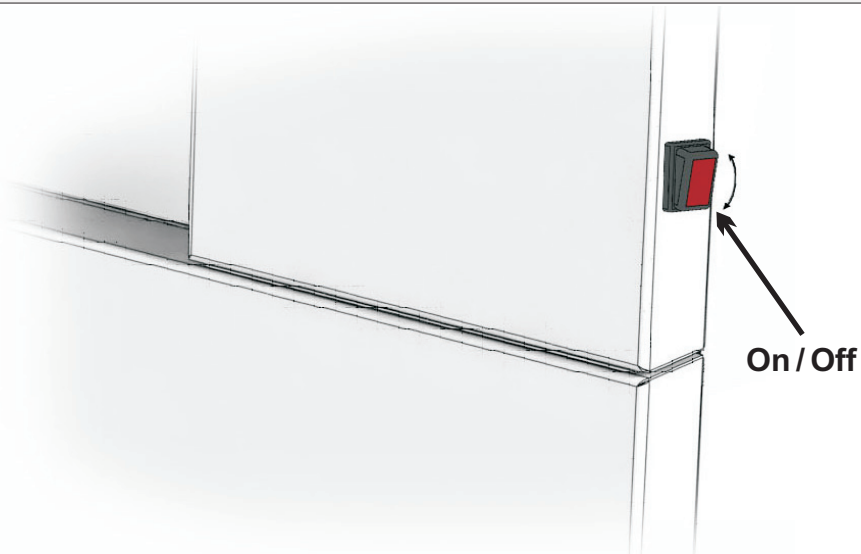

Ignition:

To turn the fire on push the ON/OFF rocker switch to the on position. The ignition unit will start sparking and the pilot and burners will ignite almost immediately.

In the event of no gas, the ignition unit will attempt to try to light up to 3 times before shutting down.

Turning off the fire:

To turn the fire off, simply flick the ON/OFF rocker switch to the off position. This will shut down the gas flow to the pilot flame and both burners.

Please ensure the gas supply is also turned off, and as an extra safety please turn off the main power supply at the house.

Basic Operation

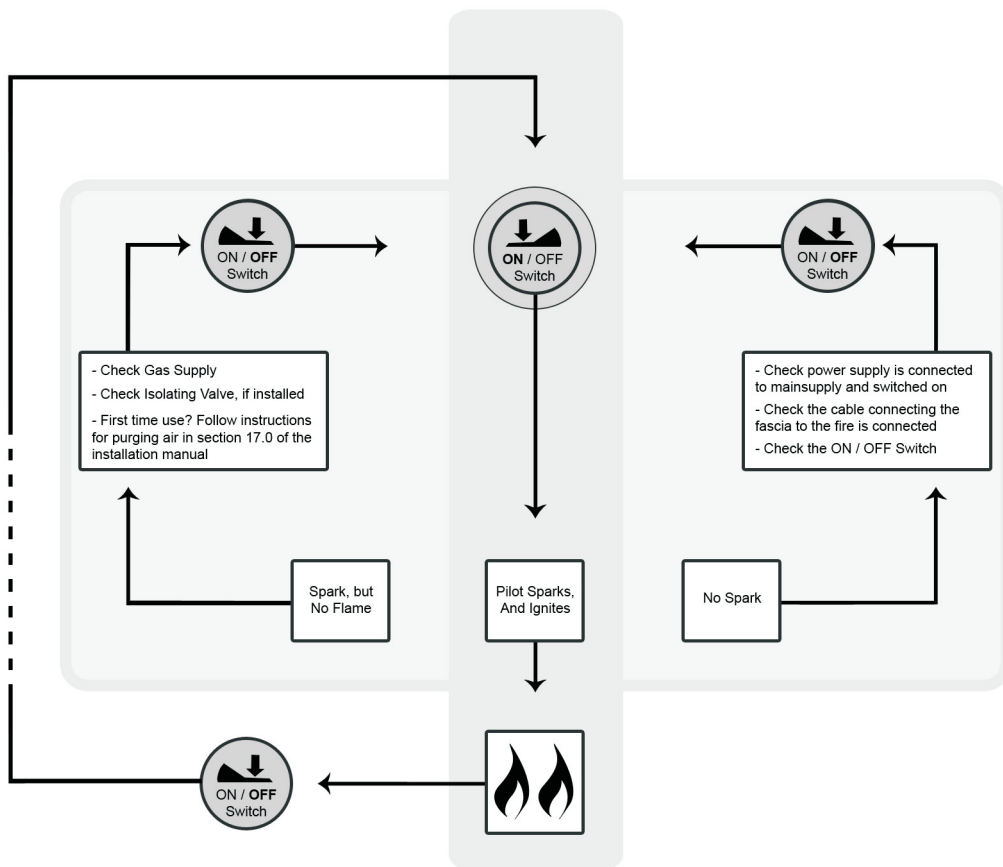

Removing the Fascia

The EF5000 Stainless Steel fascia is attached to the fire by four 'hooks' on the corners of the fascia. If you need to remove the fascia, first give the fascia a brief lift upwards as shown.

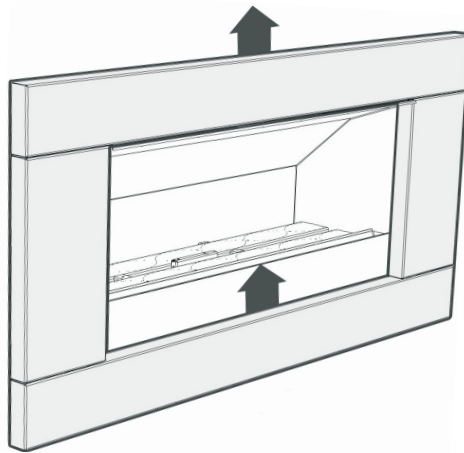

Now slide the fascia towards you until it falls into the additional slot, unplug the electrical cord. Now you can rest the Fascia on the ground.

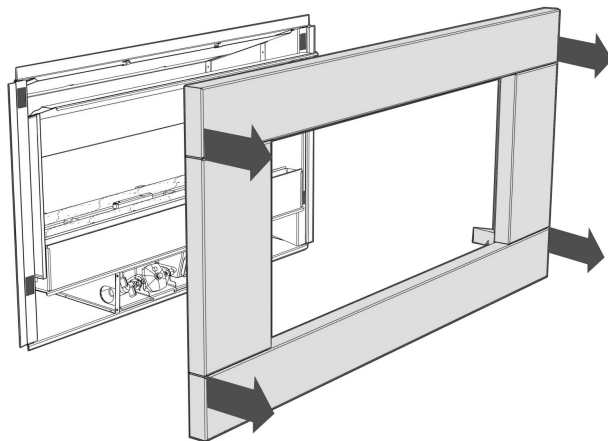

Reverse these steps to re-fit the Fascia, ensuring the two connections are correctly plugged in by testing the fire.

Cleaning your EF5000

To clean the glass and stones in the front stone tray simply reverse the steps in section 14.0 of the Installation Manual.

The glass can be cleaned using standard window cleaner. The quartz stones can be washed using soapy water

If the stainless steel fascia requires cleaning the following products are recommended; 3M Stainless steel cleaner or methylated spirits.

To clean the weather cover or the powder coated or stone fascia options warm soapy water should be used.

Cleaning of the ceramic stones and burners can be carried out using a brush and a dry cloth.

Warranty

escea

WARRANTY TERMS & CONDITIONS:

If, and only if, the Product is installed as per ESCEA's installation manual and the step by step warranty procedure has been followed as per instructions issued by ESCEA, (documented in the agent manual), and that the product is operated and maintained in accordance with ESCEA operating and maintenance instructions, then for the first period of 12 months from the date of purchase ESCEA will pay the cost of repairing or replacing any part of the Product that is deemed by ESCEA to be faulty.

For the second period of 12 months from the date of purchase ESCEA will supply replacement parts only, without charge.

Parts and Labour for the first 12months:

- a) ESCEA at its discretion may modify, adjust, repair or replace the faulty products. The warranty period on parts and labour shall be for 12 months from the acceptance date of the Products by the ESCEA retailer.
- b) Labour costs will only be reimbursed when ESCEA specified procedure has been followed, and ESCEA has authorised service work before it was carried out.

Parts for the second 12months ONLY:

- a) ESCEA at its discretion will provide replacement parts to the retailer or service agent. Faulty parts MUST be returned to ESCEA. The "parts only" warranty period shall be for 12 months and will commence 12 months after the acceptance date of the Products by the ESCEA retailer.

General Terms:

1. All repairs made within the warranty period shall be covered by warranty for a period of 3 months from the date of completion of the repair, or for the remainder of the overall product warranty, whichever is the longer.
2. If the buyer, or any other party, modifies any part of the Product within the warranty period without the written consent of ESCEA then the warranty shall be void. ESCEA may, at their sole discretion, decide that the warranty is void in relation to any part of the product, which has been modified.
3. ESCEA must be notified of all warranty claims as soon as possible, but in any event not later than 2 weeks of becoming aware of the circumstance giving rise to the claims.
4. ESCEA's liability in this warranty is limited to the repair and replacement of faulty parts or workmanship by ESCEA. No other resultant direct or indirect costs or expenses can be claimed.

escea.

