

# LINEA DUO L

[Model ADH100DL AU]

Heat Output	▪	24.0kW average peak power
Efficiency	▪	60% average
Coverage	▪	up to 250m <sup>2</sup>
Emissions	▪	1.1 grams/kg



From the industry leading Portugal supplier ADF, comes the Linea 100 Duo L Freestanding wood burning fireplace with double sided viewing and heating, ensuring a fabulous and full flame picture from both sides of the fire. Dual doors swing open for convenient reloading and showcase the flames, and lively embers all whilst providing an enchanting ambience and to 24.0kW of heat output.

Externally this stunning fire is made even more attractive by its undeniable contemporary aesthetic, large glass viewing area, with easy opening on both sides, and single air control.

Internally these fires exhibit all the traits that comes with every ADF fire, combing a 5mm steel firebox with high density firebrick that insulates the combustion chamber, enabling superior heat reflection.. In addition an automatic flue damper system is included to significantly reduce smoke ingress to the room on re-fuelling. This is a must have with an larger size firebox., and comes included with every ADF fire.

The ADF Duo is all about contemporary lines and a strong sense of style. Expertly constructed by some of the worlds finest craftsman ADF incorporates their heritage and time-honoured tradition into every design, making the ADF Linea 100 Duo L the ultimate fireplace for dual heating. The Linea 100 is also available as a single sided wood burning fireplace.

## Clearances

Hearth depth inc 450mm in front. Thickness: Equal to 6mm Compressed Board or equivalent	Width	Depth	Thickness
Parallel No Shielding	1240	1450	6

Top View

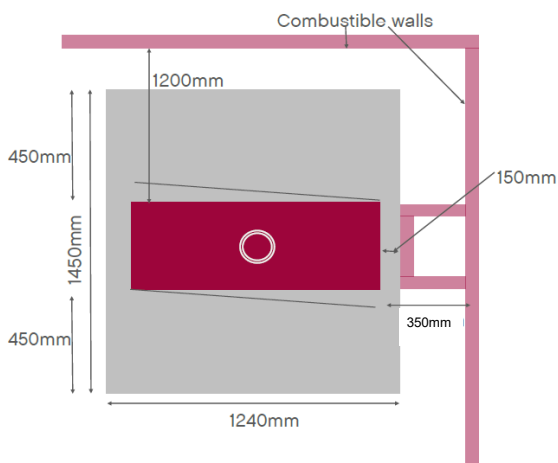

## Dimensions

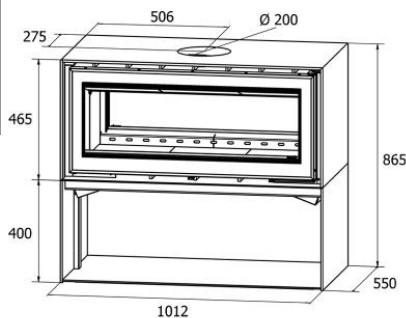

- Open base included [exclusive to the Duo L]
- Constructed using high-strength 5mm quality black steel
- Automatic flue damper system significantly reduces smoke ingress to the room on re-fueling
- High density vermiculite lining system insulates the combustion chamber, providing better heat reflection
- Superior air wash system keeps the glass clean for unparalleled fire viewing
- Vertical smoke exit through the top
- Weight : 307kilos
- Maximum log width : 300mm
- Flue Spigot Size : 200mm
- Internal Firebox : 880[w] x 405[d] x 245-280[h]
- Viewing Area : 920[w] x 380[h]
- Warranty : Limited 5 years manufactures

Information supplied is to assist you in your choice of a suitable fire. It is not intended to be all the information required to install the fire and does not replace the installation manual which provided more detailed information. In the interest of product development ADF reserves the right to change specifications without prior notice.

Flue Shield Configuration	Rear	Side	Front	Corner
Parallel No Shielding	1200	350	450	N/A

CLEARANCES BASED ON INSTALLATION HAWKWIND 200MM TRIPLE SKIN FLUE KIT.



All measurements are in millimetres unless otherwise stated.