



# Regency HZO42 Outdoor Gas Fireplace

## Owners & Installation Manual

MODELS: HZO42-NG  
HZO42-ULPG



[www.regency-fire.com](http://www.regency-fire.com)

### LISTINGS AND CODE APPROVALS

These gas appliances have been tested in accordance with AS4565 / NZS 4558 and have been certified by the IAMPO Oceana for installation and operation as described in these Installation and Operating Instructions.

Your unit should be serviced annually by an authorised service person.

**WARNING: FOR OUTDOOR USE ONLY**

### WARNING:

If the information in these instructions are not followed exactly, a fire or explosion may result causing property damage, personal injury or loss of life.

### FOR YOUR SAFETY

Do not store or use gasoline or other flammable vapours and liquids in the vicinity of this or any other appliance.

Installation and service must be performed by a qualified installer, service agency or the gas supplier.

### FOR YOUR SAFETY

What to do if you smell gas:

- Do not try to light any appliance
- Do not touch any electrical switch: do not use any phone in your building.
- Immediately call your gas supplier from a neighbour's phone. Follow the gas supplier's instructions.
- If you cannot reach your gas supplier, call the fire department.

### WARNING:

Improper installation, adjustment, alteration, service or maintenance can cause injury or property damage. Read the installation, operating and maintenance instructions thoroughly before installing or servicing this equipment.

*Installer:* Please complete the details on the back cover and leave this manual with the homeowner.

*Homeowner:* Please keep these instructions for future reference.

---

## To the New Owner:

Congratulations!

You are the owner of a state-of-the-art Gas Fireplace by REGENCY®. The HZO42 Outdoor fireplace has been designed to provide you with all the warmth and charm of a fire at the flick of a switch. As it also bears our own mark, it promises to provide you with economy, comfort and security for many trouble free years to follow. Please take a moment now to acquaint yourself with these instructions and the many features of your Regency® Fireplace.



# WARNING!



**HOT GLASS WILL  
CAUSE BURNS**

**DO NOT TOUCH GLASS  
UNTIL COOLED**

**NEVER ALLOW CHILDREN  
TO TOUCH GLASS**

---

## **WARNING**

DO NOT turn your fireplace on via any means or allow to be turned on unless you have conducted a thorough inspection of the area surrounding the fireplace immediately prior to its use, and you have satisfied yourself that there are no materials or other items in proximity to the fireplace which could present a fire risk.

DO NOT turn your fireplace on via any means or allow to be turned on if there are any unsupervised children, infirm or pets in the area surrounding the fireplace.

DO NOT use this fireplace, unless you have read this Manual, and strictly adhere to the user requirements and warnings set out in this Manual.

## **RELEASE**

Without limiting any other acknowledgement, release or indemnity given by you, or limitation of liability, in favour of Fireplace Products Pty Ltd ("Company"), you irrevocably and unconditionally acknowledge and agree that failure to comply with, or strictly adhere to, the requirements and warnings set out in this Manual ("User Requirements") may result in:

1. damage to the fireplace;
2. damage to property;
3. a house fire;
4. severe burns or other personal injury; and/or
5. death.

Subject to any remedy, guarantee, term, condition, warranty, undertaking, inducement or representation, implied or imposed by any legislation which cannot lawfully be excluded or limited, and to the maximum extent permitted by law:

1. the Company will not be liable for any damage, personal injury or death arising out of or in connection with your failure to comply with any User Requirement; and
2. you release the Company from all claims, actions, proceedings, liabilities, losses and damages in relation to death, any personal injury or property damage arising out of or in connection with your failure to comply with any User Requirement.

**SAFETY LABEL**

Copy of Safety Decal .....5

**DIMENSIONS**

Unit Dimensions .....6

**INSTALLATION**

Important Message .....7  
Before You Start.....7  
General Safety Information.....7  
Installation Checklist.....8  
Locating Your Gas Fireplace.....8  
Outdoor Appliance Installation Summary .....9  
Minimum Clearances to Combustibles .....10  
Framing Dimensions.....11  
Mantel Clearances.....12  
Non Combustible Requirements.....12  
Non Combustible Facing Installation .....13  
Finishing .....14  
Gas Line Installation.....15  
Pilot Adjustment.....15  
Gas Pipe Pressure Testing .....15  
880 S.I.T. Valve Description .....15  
Aeration Adjustment .....15  
Unit Assembly Prior to Installation.....16  
    Standoff Assembly .....16  
    Nailing Strips.....16  
Wall Switch Installation .....17  
Wiring Diagram.....18  
Inner Panel Installation .....19  
Glass Crystal Installation .....20  
Volcanic Stone Installation.....21

Optional Log Set Installation.....22  
Heat Deflector Installation .....24  
Faceplate Installation.....25  
Glass Wind Shield Installation .....26  
Weather Cover Installation / Removal .....26  
Assembly Instructions for a Steel Stud Framing Kit for  
HZO42.....27

**OPERATING INSTRUCTIONS**

Operating Instructions .....32  
Lighting Procedure .....32  
Shutdown Procedure .....32  
First Fire .....32  
Copy of Lighting Plate Instructions .....33

**MAINTENANCE**

Maintenance Instructions .....34  
Valve Assembly Replacement .....35  
Battery Replacement.....36  
Digital Fireplace Burner Control .....37  
Gas Maintenance .....38

**PARTS**

Main Assembly .....39  
Burner Assembly .....40  
Accessories .....41

**WARRANTY**

Limited Warranty .....42

This is a copy of the data badge that accompanies each HZO42 Outdoor Fireplace. We have printed a copy of the contents here for your review.

**NOTE:** Regency® units are constantly being improved. Check the label on the unit and if there is a difference, the label on the unit is the correct one.

# Regency Gas Fireplace

	○	○
Gas Type	NG	ULPG
Model	<b>HZO42-NG</b>	<b>HZO42-ULPG</b>
Gas Consumption	47 MJ/h	47 MJ/h
Manifold Pressure	0.88 kPa	2.49 kPa
Injector Size	1x#29 3.45mm	1x#47 1.99mm
Approval # GMK10048 AS/NZS 5263.1.4/8		

Electrical: 6 VDC

**N2134**      Serial Number **378**

Distributed by:  
Western Australia:  
**Air Group Australia**  
28 Division St  
Welshpool WA 6106

Eastern Australia  
**Fireplace Products**  
Australia Pty. Ltd.  
1 Conquest Way  
Hallam, VIC 3803

New Zealand:  
**Aber Holdings Ltd.**  
17 Mainstreet Place,  
Te Rapa,  
Hamilton, New Zealand

To be installed by an authorised person in accordance with installation instructions provided with the appliance.

918-977b

**Primarily a decorative appliance - not certified as a space heater.**

**DO NOT** OPERATE THIS APPLIANCE BEFORE READING THE INSTRUCTIONS BOOKLET.

**DO NOT** PLACE ARTICLES ON OR AGAINST THIS APPLIANCE

**DO NOT** USE OR STORE FLAMMABLE MATERIALS NEAR THIS APPLIANCE.

**DO NOT** SPRAY AEROSOLS IN THE VICINITY OF THIS APPLIANCE WHILE IN OPERATION.

**DO NOT** OPERATE WITH PANELS, COVERS OR GUARDS REMOVED FROM THIS APPLIANCE.

**DO NOT** ENCLOSE THIS APPLIANCE.

**DO NOT** MODIFY THIS APPLIANCE.

908-602b

# dimensions

## UNIT DIMENSIONS

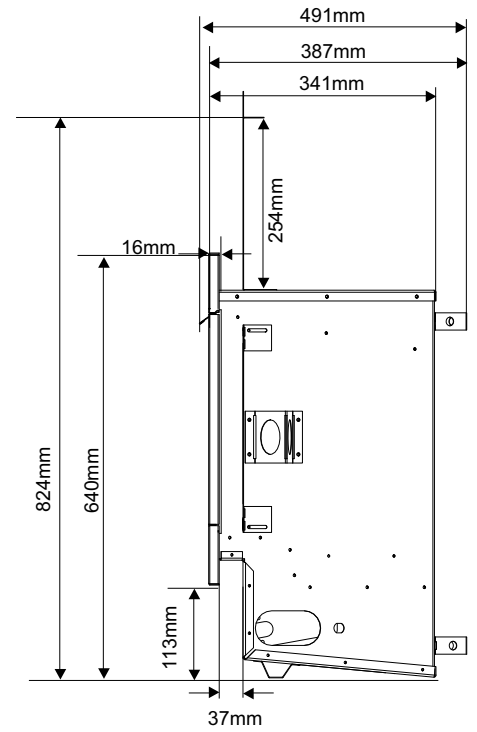
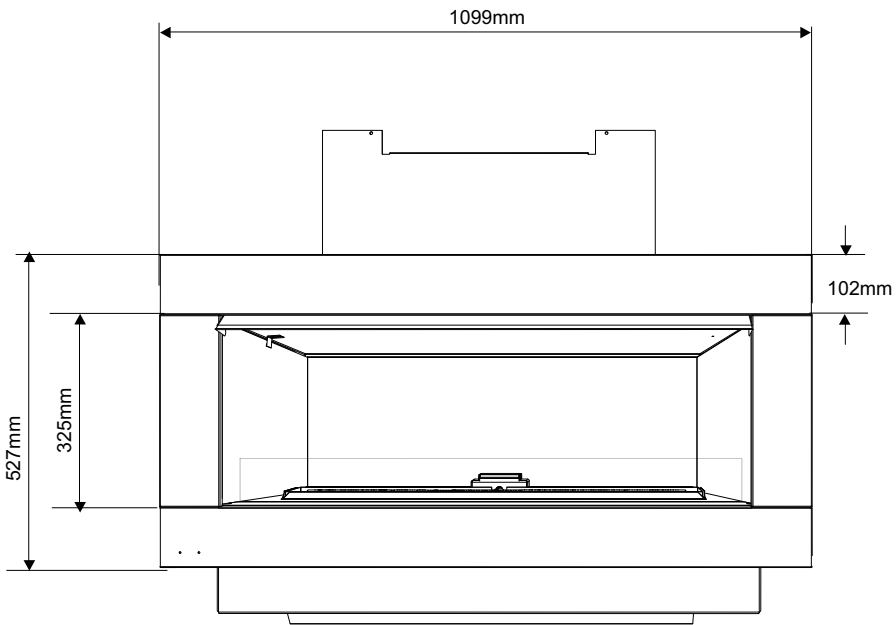
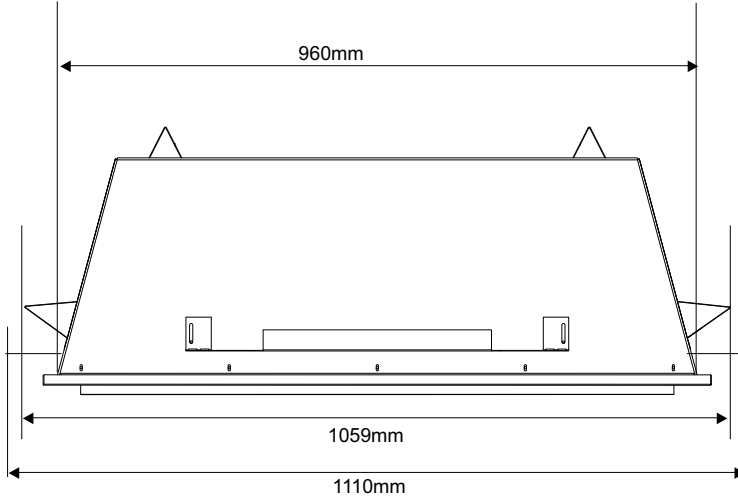

## IMPORTANT MESSAGE SAVE THESE INSTRUCTIONS

The HZO42 Gas Fireplace must be installed in accordance with these instructions. Carefully read all the instructions in this manual first. Consult the "authority having jurisdiction" to determine the need for a permit prior to starting the installation. It is the responsibility of the installer to ensure this fireplace is installed in compliance with manufacturers instructions and all applicable codes.

## BEFORE YOU START

Safe installation and operation of this appliance requires common sense, however, we are required to make you aware of the following:

**INSTALLATION AND REPAIR SHOULD BE DONE BY AN AUTHORISED SERVICE PERSON. THE APPLIANCE SHOULD BE INSPECTED BEFORE USE AND AT LEAST ANNUALLY BY A PROFESSIONAL SERVICE PERSON. MORE FREQUENT CLEANING MAY BE REQUIRED DUE TO EXCESSIVE LINT FROM CARPETING, BEDDING MATERIAL, ETC. IT IS IMPERATIVE THAT CONTROL COMPARTMENTS, BURNERS AND CIRCULATING AIR PASSAGEWAYS OF THE APPLIANCE BE KEPT CLEAN.**

**ANY GUARD OR OTHER PROTECTIVE DEVICE REMOVED FOR SERVICING THE APPLIANCE MUST BE REPLACED PRIOR TO OPERATING THE APPLIANCE**

**WARNING: FAILURE TO INSTALL THIS APPLIANCE CORRECTLY WILL VOID YOUR WARRANTY AND MAY CAUSE A SERIOUS FIRE.**

**CHILDREN AND ADULTS SHOULD BE ALERTED TO THE HAZARDS OF HIGH SURFACE TEMPERATURES, ESPECIALLY THE FIREPLACE GLASS AND FACEPLATE, AND SHOULD STAY AWAY TO AVOID BURNS OR CLOTHING IGNITION.**

**THIS APPLIANCE SHALL BE USED ONLY OUTDOORS IN A WELL-VENTILATED SPACE AND SHALL NOT BE USED IN A BUILDING, GARAGE OR ANY OTHER ENCLOSED AREA.**

**DO NOT USE THIS APPLIANCE IF ANY PART HAS BEEN UNDER WATER. IMMEDIATELY CALL A QUALIFIED SERVICE TECHNICIAN TO INSPECT THE APPLIANCE AND TO REPLACE ANY PART OF THE CONTROL SYSTEM AND ANY GAS CONTROL WHICH HAS BEEN UNDER WATER.**

**CLOTHING OR OTHER FLAMMABLE MATERIAL SHOULD NOT BE PLACED ON OR NEAR THE APPLIANCE.**

**YOUNG CHILDREN SHOULD BE CAREFULLY SUPERVISED WHEN THEY ARE IN THE SAME AREA AS THE APPLIANCE. TODDLERS, YOUNG CHILDREN AND OTHERS MAY BE SUSCEPTIBLE TO ACCIDENTAL CONTACT BURNS. A PHYSICAL BARRIER IS RECOMMENDED IF THERE ARE AT RISK INDIVIDUALS IN THE HOUSE. TO RESTRICT ACCESS TO A FIREPLACE OR STOVE, INSTALL AN ADJUSTABLE SAFETY GATE TO KEEP TODDLERS, YOUNG CHILDREN AND OTHER AT RISK INDIVIDUALS OUT OF THE ROOM AND AWAY FROM HOT SURFACES.**

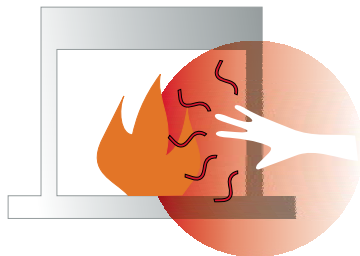

## GENERAL SAFETY INFORMATION

- 1) The installation must conform with local codes or, in the absence of local codes, with *CAN/CSA-B149.1*, Natural Gas and Propane Installation Code or *CAN/CSA-B149.2*, Propane installation code the Natural Gas Fuel Code, *ANSI Z223.1/NFPA 54 / AS5601 / AG601*.
- 2) The appliance when installed, must be electrically grounded in accordance with local codes, or in the absence of local codes with the Canadian Electrical Code *CSA C22.1* or with the National Electrical Code, *ANSI/NFPA 70 / NZS3100 & AS5601 / AG601*.
- 3) See general construction and assembly instructions. The appliance should be enclosed.
- 4) Inspect the burner before each use of the appliance for blockage and any signs of deterioration.

- 5) To prevent injury, do not allow anyone who is unfamiliar with the operation to use the fireplace.
- 6) Wear gloves and safety glasses for protection while doing required maintenance.
- 7) Maximum gas inlet pressure = 3.5 kPa
- 8) Under no circumstances should this appliance be modified. Parts that have to be removed for servicing should be replaced prior to operating this appliance.
- 9) Installation and any repairs to this appliance should be done by a qualified service person. A professional service person should be called to inspect this appliance annually. Make it a practice to have all of your gas appliances checked annually.
- 10) Under no circumstances should any solid fuels (wood, paper, cardboard, coal, etc.) be used in this appliance.
- 11) The appliance and its individual shutoff valve must be disconnected from the gas supply piping system during any pressure testing of that system at test pressures in excess of 1/2 psi (3.5kPa).  
The appliance must be isolated from the gas supply piping system by closing its individual manual shutoff valve during any pressure testing of the gas supply piping system at test pressures equal to or less than 1/2 psi (3.5 kPa).
- 12) The appliance area must be kept clear and free of combustible materials, (gases and other flammable vapours and liquids).

*It is highly recommended to protect the interior from moisture (rain, snow). Cover the enclosure opening when not in use. This fireplace is only for use with the type of gas indicated on the rating plate. This fireplace is not convertible for use with other gases, unless a certified kit is used.*

- 13) Cover **must** be removed when burner is in operation.
- 14) When not using appliance for extended periods of time - turn off gas supply.

# installation

## INSTALLATION CHECKLIST

Installation in accordance with AS/NZS5601.

- 1) Locate appliance:
  - a) Refer to "Locating Your Gas fireplace" section
  - b) Clearances to Combustibles (Refer to "Clearances" section)
  - c) Mantel Clearances (Refer to "Combustible Mantel Clearances" section)
  - d) Framing & Finishing Requirements (Refer to "Framing & Finishing" section)
- 2) Top Facing Support and Side Nailing Strips (Refer to "Unit Assembly Prior to Installation" Section). **Note:** Must be done before installing unit into place.
- 3) Drain Installation.
- 4) Install ON/OFF switch - ensure it is in the OFF position.
- 5) Make gas connections - test for leaks.
- 6) Install 4 "AA" batteries.
- 7) Install standard and optional features. Refer to the following sections:
  - a. Inner Panel
  - b. Glass Crystals
  - c. Pebble Installation (optional)
  - d. Garden Stone Installation (optional)
  - e. Log Installation (optional)
  - f. Glass Wind Shield Installation
  - g. Heat Deflector Installation
  - h. Faceplate Installation
  - i. Weather Cover Installation
- 8) This appliance shall not be installed or used indoors.
- 9) Final check.

### This includes:

- 1) Clocking the appliance to ensure the correct firing rate (rate noted on label), after burning appliance for 15 minutes.
- 2) If required, adjusting the primary air to ensure that the flame does not carbon. First allow the unit to burn for 15-20 min. to stabilize.

**CAUTION: Any alteration to the product that causes sooting or carboning that results in damage is not the responsibility of the manufacturer.**

## LOCATING YOUR GAS FIREPLACE

- 1) This appliance must only be used in a well ventilated area.
- 2) When selecting a location for your fireplace, ensure that the clearances are met.
- 3) This appliance must be installed in an open-air situation with natural ventilation, without stagnant areas, where gas leakage and products of combustion are rapidly dispersed by wind and natural convection.
- 4) Certain materials or items, when placed under or near the appliance, will be subjected to radiant heat and could become damaged.
- 5) Typically an outdoor space is not enclosed but, any enclosure in which the appliance is used shall comply with one of the following:

An enclosure with walls on all sides, but at least one permanent opening at ground level and no overhead cover.

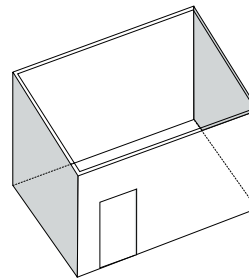

Within a partial enclosure that includes an overhead cover and no more than two walls.

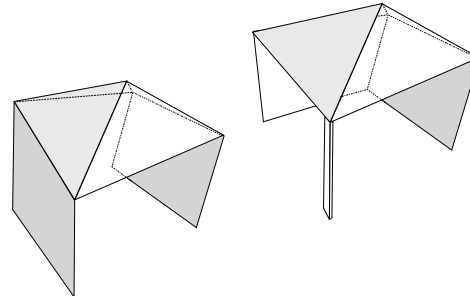

Within a partial enclosure that includes an overhead cover and more than two walls, the following shall apply:

- At least 25% of the total wall area is completely open, and
- At least 30% of the remaining wall area is open and unrestricted

30% or more in total of the remaining wall area is open and unrestricted.

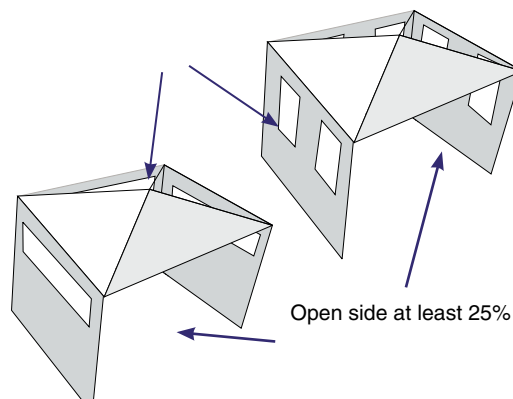

Open side at least 25% of total wall area

In case of balconies, at least 20% of the total wall area shall be and remain open and unrestricted.



## IMPORTANT INFORMATION FOR OUTDOOR FIREPLACE INSTALLATIONS

- Never insulate around the body of the unit
- Excessive heat retention in the firebox will lead to component failure and fireplace malfunction
- Excessive heat retention will also increase the risk of fire inside the chase
- Heat retention can cause “Oil-canning” and damage the fireplace due to overheating
- Do not build up a wall of any type in front or to the sides of the appliance, higher than the firebox opening. This will create a pressure zone at the firebox and will prevent the unit from venting
- This is an outdoor appliance with a built-in drain. This drain should be installed and connected in all applications as per the instructions in this manual
- Inadequate drainage will cause rust and reduce the life of your appliance, this is not protected by warranty

### COMPONENTS IN OUTDOOR APPLIANCES

- Outdoor units use the same consistent, reliable Electronic components used in most Regency “E” units
- Installed correctly, these components will be subjected to far lower temperatures than indoor units, which have been certified as safe from heat etc
- Working gas pressures are as critical in outdoor products as they are in indoor products, even more important in Electronic systems

### COMMON MISCONCEPTIONS REGARDING OUTDOOR FIREPLACES

- There is a common misconception that being outdoors, an Outdoor Fireplace will function, regardless of circumstances,
- Outdoor fireplaces require the same amount of ventilation as indoor units, often more
- Outdoor units require adequate ventilation to the atmosphere, which in turn provides ongoing circulatory combustion air
- This type of Appliance Vents.
- All Outdoor Fireplace Products have the same need for Air/Oxygen, and an ability to Vent
- Even though the appliance is outdoors, this doesn’t mean it is getting adequate air
- Requirements are not specific to Regency units
- Read and follow critical location guidelines in this manual

### UNDERSTANDING OUTDOOR APPLIANCE REQUIREMENTS

- Don’t overlook the obvious
- Widen your margin for error
- Combustion always requires the same three elements
- Only the quantities and volumes change



### IMPORTANT THINGS TO REMEMBER

- Correct Working Gas pressure is critical on “E” units
- Wherever possible avoid locating on a flat wall in a tight corner
- Floor space doesn’t count as “open area”
- Install to the manual specs for framing and **do not insulate** unit or enclosure
- Framing enclosure must at least meet minimum dimensional specs as per the installation manual
- Only Regency approved media should be used in the firebox (i.e. stones/glass)
- Be aware of pressure zones due to location (i.e. facing the ocean)
- Open walls and doorways to outside air are beneficial to the performance of an outdoor appliance
- Fixed roof/ceiling open areas count towards the total open area overall requirement
- Screens create 40% or more air restriction
- Screened areas are restrictions and reduce open air space, calculate area based on a **closed** screen
- The biggest problems are created by lack of airflow for the appliance
- Outdoor fireplaces are often built-in systems and incorrect installation can result in high repair costs
- Units must not be modified or altered in any way

### ANTICIPATED ISSUES CAUSED BY INCORRECT LOCATION OR INSTALLATION

- Unit shutting down intermittently
- Overheating of components leading to failure
- Lifting flame
- Poor flame package (i.e. all to one side, lazy flame)
- Failure to ignite
- Excess carbon
- Safety issues and concerns created from the byproducts of combustion

### OUTDOOR APPLIANCES REQUIRE VENTING

- Outdoor appliances must be installed in: open-air situations with natural ventilation and without stagnant areas
- Any gas leakage and products of combustion need to be rapidly dispersed by wind and natural convection
- Typically outdoor spaces are not enclosed, however, failure to adhere to installation guidelines, may cause the outdoor fireplace to be affected by wind or air pressure inside the enclosure
- **ANY** enclosure in which the appliance is used shall comply with one of the diagrams on the previous page.

### OUTDOOR APPLIANCE INSTALLATION SUMMARY

- All walls + overhead cover = 100% total area
- One of four walls or full overhead area must be totally open, plus—one of remaining walls must have a fixed opening
- All outdoor fireplaces/fire tables require total **natural** ventilation of 50% open space

## MINIMUM CLEARANCES TO COMBUSTIBLES

The clearances listed below are minimum distances unless otherwise stated.

A major cause of fires is failure to maintain required clearances (air space) to combustible materials. It is of the greatest importance that this fireplace be installed only in accordance with these instructions.

**Caution Requirements**  
The top, back and sides of the fireplace are defined by standoffs. The metal ends of the standoff may **NOT** be recessed into combustible construction.

**WARNING**  
Fire hazard is an extreme risk if these clearances (air space) to combustible materials are not adhered to. It is of greatest importance that this fireplace be installed only in accordance with these instructions.

### HZO42 Clearance Requirements

Clearance:	Dimension	Measured From:
<b>A: Sidewall</b>	280 mm	Side of Fireplace Opening
<b>B: Ceiling</b>	914 mm	Top of Fireplace Opening
<b>C: Mantel Height (min.)</b>	457 mm	Top of Fireplace Opening
<b>D: Mantel Depth (max.)</b>	304 mm	From Wall
<b>E: Alcove Width</b>	1148 mm	Wall to Wall (Minimum)
<b>F: Alcove Depth</b>	914 mm	Front to Back Wall (Maximum)
<b>Notes:</b>	0mm	No Hearth Required

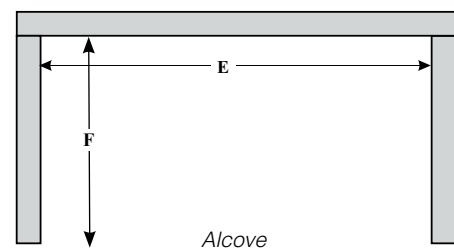
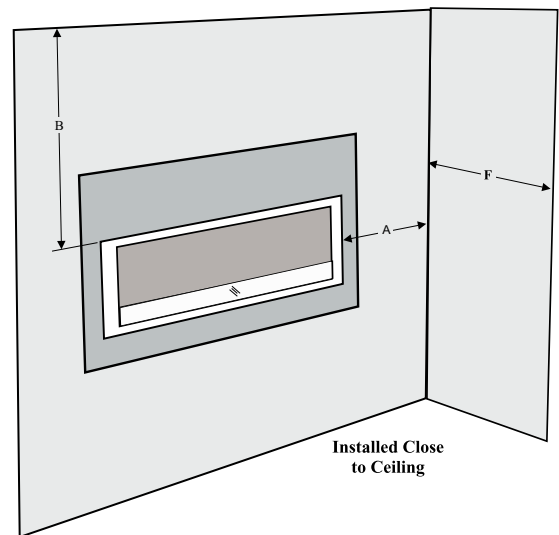
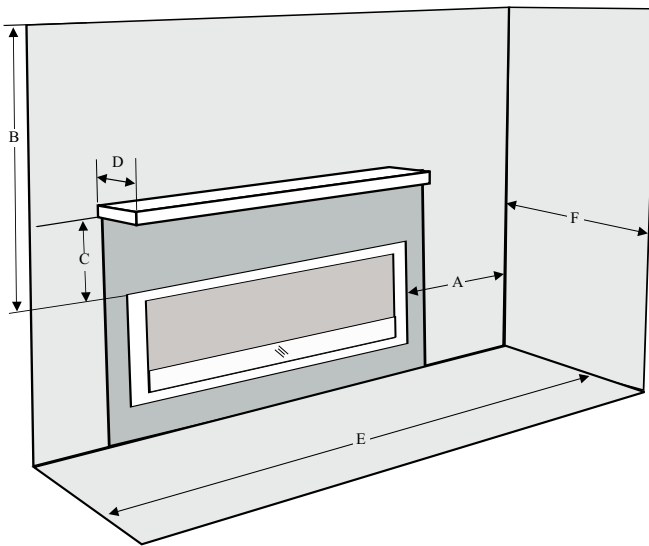

**FRAMING DIMENSIONS**

Framing Dimensions	Description	HZO42
A	Header Height	830 mm
B	Side Stud Width	1072 mm
C	Minimum framing depth	508 mm
D	Minimum Height to Combustibles	1334 mm
E	Minimum framing width	1524 mm
F	Corner Wall Depth	1027 mm
G	Corner Facing Wall Width	1376 mm
H	Gas Connection Opening Height	51 mm
I	Gas Connection Height	98 mm
J	Gas Connection Inset	20 mm
K	Gas Connection Opening Width	98 mm

\* Framing depth measurement is noted with the nailing strips set as far forward on the firebox as possible. The nailing strips can be adjusted back up to 25mm to allow for varying thicknesses in non-combustible material & wall finishes.

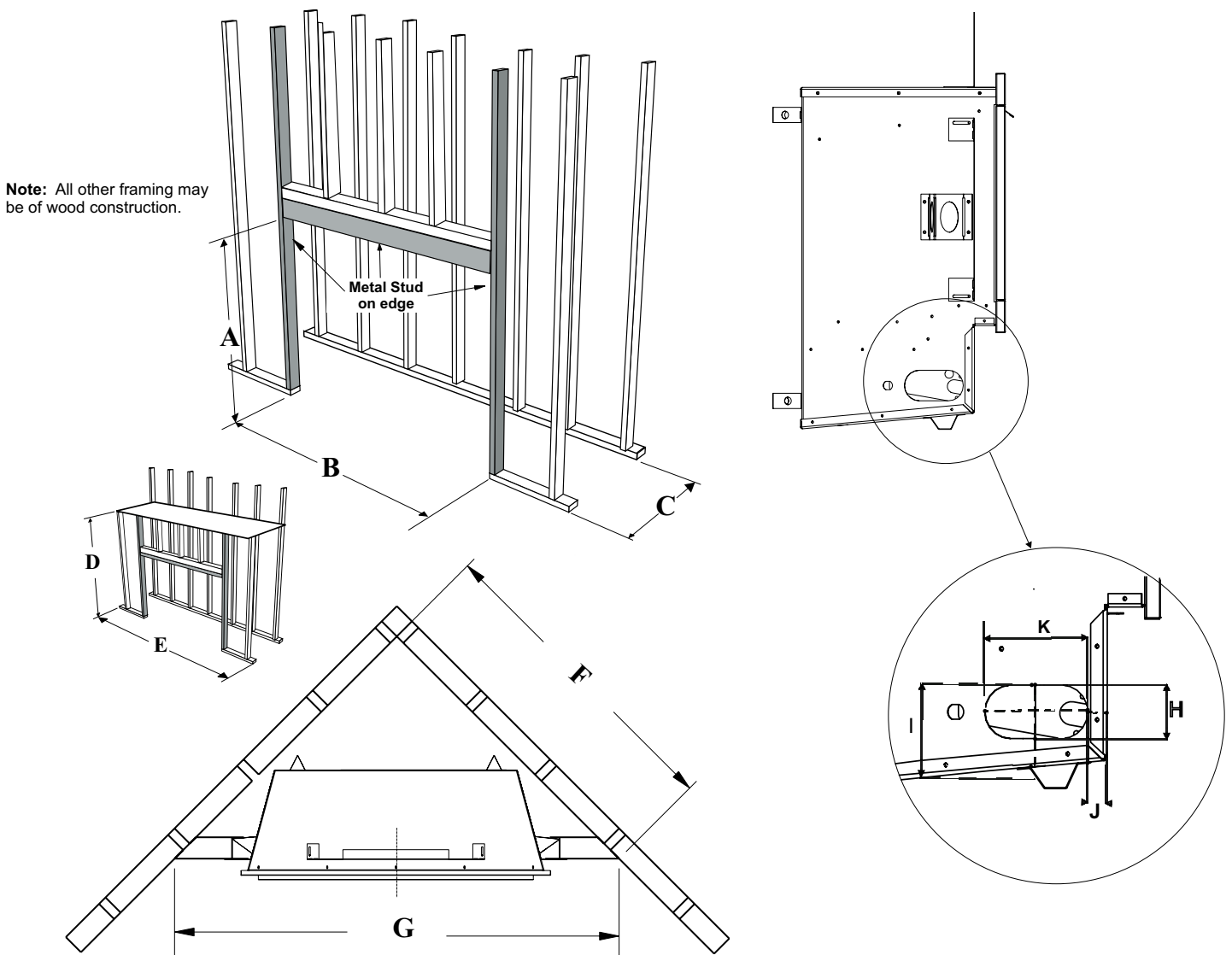

# installation

## MANTEL CLEARANCES

Due to the extreme heat this fireplace emits, the mantel clearances are critical. Combustible mantel clearances from top of front facing are shown in the diagram on the right.

**Note:** Ensure the paint that is used on the mantel and the facing is "heat resistant" or the paint may discolour.

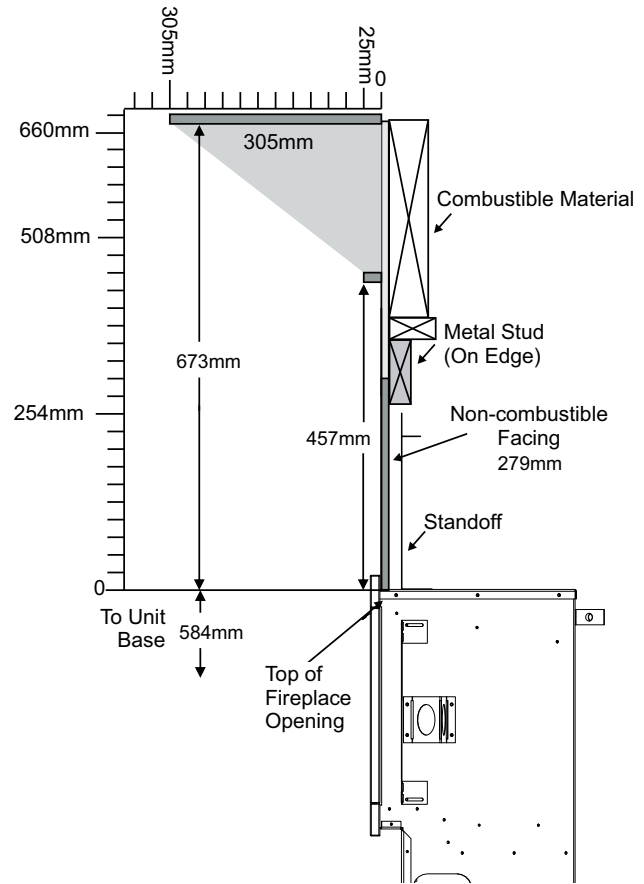

## NON-COMBUSTIBLE REQUIREMENTS

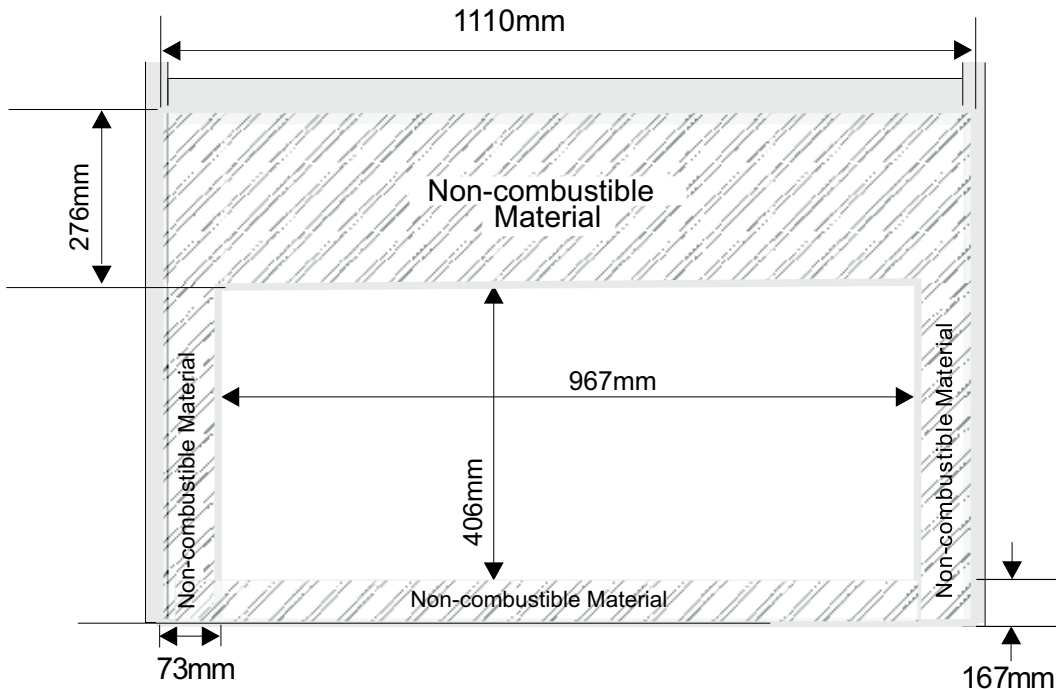

A minimum thickness of 12 mm non-combustible board compliant with AS1530-1 and AS1530-3 is required.

## NON COMBUSTIBLE FACING INSTALLATION

### IMPORTANT NOTE:

**Prior to installation of non-combustible materials by others, check and inspect carefully for any hairline cracks and or damage to board. The non combustible board must be a minimum of 12mm thick and comply with AS1530-1 and AS1530-3. Material which is thinner may crack as a result due to the high temperatures this appliance emits.**

- 1) Using screws for use with non-combustible boards-secure non-combustible material around unit, framing and top nailing strip every 150mm  
**Important Note: To avoid cracking the board-pre-drill holes prior to securing to unit/framing.**
- 2) Wipe any debris/dust from the non-combustible material and dry wall.
- 3) Prior to securing, it is mandatory to prime the facing and edges using a quality primer. This will ensure proper adhesion of the tape, filler and paint.  
 Failure to follow this procedure will result in cracked seams.
- 4) Tape the seams using a mesh type tape.
- 5) Fill seams as normal. Avoid using filler which shrinks excessively. Filler must be cured as per manufacturer's recommendations.
- 6) Prime wall for a second time for proper adhesion of paint.
- 7) Paint walls using a high quality paint which will withstand the high temperatures being emitted from this appliance.

**NOTE:** When applying 12mm minimum non-combustible board to frame-work it is advisable to use the same 12mm minimum non-combustible board on the whole front face of the wall.

When using standard fascia cut out the clean edge trim opening plus a further 10mm border.

The above will allow for possible expansion and contraction.

### IMPORTANT

Regency Fireplace Products are designed, produced, tested and certified to the highest industry standards. The finishing of the walls surrounding Regency is as critical as the installation itself. The temperatures around linear gas fireplaces are typically higher than would be acceptable for the combustible materials. Your Regency Fireplace is no exception to this rule. Therefore, the units are specified with non-combustible required materials to specific dimensions above and around the units. This is due to these areas reaching higher temperature levels than required/acceptable for a combustible material. To obtain the best, most durable finish around your fireplace, this calls for a high level of care and attention to the preparation and finish around this appliance, using only the highest quality materials, able to withstand the temperatures produced.

By following the installation instructions in the manual exactly, you will increase your chances for a damage free finish.

Every precaution is taken in providing the recommendations on preparation and finish, given the variation in paint quality, with temperature limits and workmanship applied to or used in any application surrounding the fireplace. This includes framing as well as finishing.

Over time natural convection from any fireplace can cause discoloration in the area directly above the appliance. Lower quality paints, under prepared finishes, poor applications and any framing discrepancies or in the installation can cause this discoloration process to be expedited.

Discoloration is not the responsibility of Regency Fireplace Products, we believe careful attention to the recommendations provided here will be result in aesthetically pleasing result free of issues outlined above.

# installation

## FINISHING

### IMPORTANT FINISHING DETAIL NOTE:

Before placing unit into final position - it is important to know the total thickness / height of finished hearth. The base of the fireplace should be level or higher than the finished hearth height.

If material such as brick, stone, etc extends past the faceplate depth ( 38mm), when finishing around the faceplate, the minimum opening dimensions noted below must be adhered to ensuring for the removal of the faceplate and for the safe operation of this appliance.

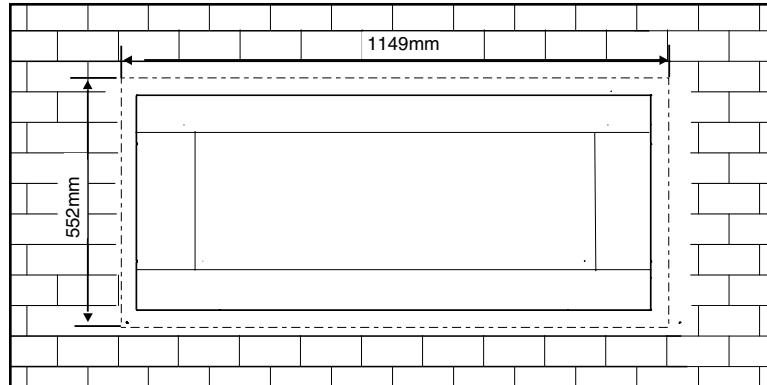

For material such as brick, stone, etc that extend up to 38mm, the minimum opening dimensions noted below must be adhered, when finishing around the faceplate. This is to ensure the removal of the faceplate and for the safe operation of this appliance.

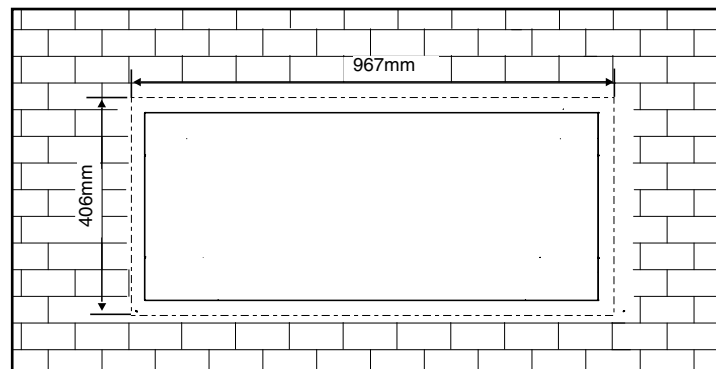

Unit shown without faceplate

For facing/finishing material over 38mm thick, use the outer cut out for your faceplate template.

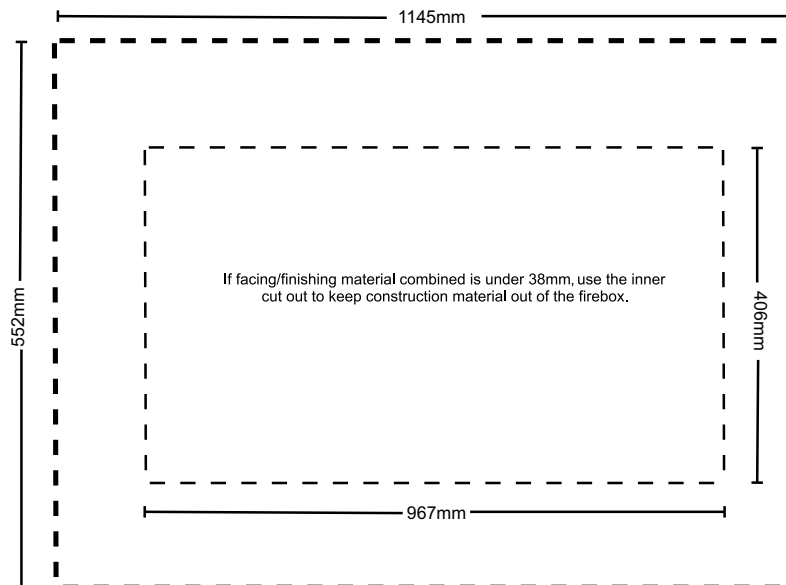

HZO42-NG SYSTEM DATA	
Max. Supply Pressure	14" WC (3.49 kPa)
Min. Supply Pressure	5" WC (1.25 kPa)
Manifold Pressure	3.5" WC (0.88 kPa)
Orifice Size	#29 DMS
Maximum Input	47 MJ/h

HZO42-ULPG SYSTEM DATA	
Max. Supply Pressure	14" WC (3.49 kPa)
Min. Supply Pressure	11" WC (2.73 kPa)
Manifold Pressure	10" WC (2.49 kPa)
Orifice Size	#47 DMS
Maximum Input	47 MJ/h

## PILOT ADJUSTMENT

Periodically check the pilot flames. Correct flame pattern has two strong blue flames: 1 flowing around the flame sensor and 1 flowing across the burner (it does not have to be touching the burner).

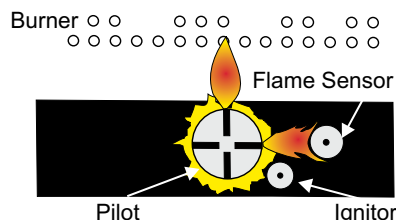

**Note:** If you have an incorrect flame pattern, contact your Regency® dealer for further instructions.

Incorrect flame pattern will have small, probably yellow flames, not coming into proper contact with the rear burner or flame sensor.

## GAS PIPE PRESSURE TESTING

The appliance must be isolated from the gas supply piping system by closing its individual manual shut-off valve during any pressure testing of the gas supply piping system at test pressures equal to or less than 1/2 psig. (3.45 kPa). Disconnect piping from valve at pressures over 1/2 psig (3.45 kPa).

The manifold pressure is controlled by a regulator built into the gas control, and should be checked at the pressure test point.

**Note:** To properly check gas pressure, both inlet and manifold pressures should be checked using the valve pressure ports on the valve.

- 1) Make sure the valve is in the "OFF" position.
- 2) Loosen the "IN" and/or "OUT" pressure tap(s), turning counterclockwise with a 1/8" wide flat screwdriver.
- 3) Attach manometer to "IN" and/or "OUT" pressure tap(s) using a 5/16" (8mm) ID hose.
- 4) Light the pilot and turn the valve to "ON" position.
- 5) The pressure check should be carried out with the unit burning and the setting should be within the limits specified on the safety label.
- 6) When finished reading manometer, turn off the gas valve, disconnect the hose and tighten the screw (clockwise) with a 1/8" flat screwdriver.  
**Note: Screw should be snug, but do not over tighten.**

## 880 S.I.T. VALVE DESCRIPTION

- 1) Pilot Adjustment
- 2) Outlet Pressure Tap
- 3) Inlet Pressure Tap
- 4) Pilot Outlet
- 5) Main Gas Outlet
- 6) Main Gas Inlet

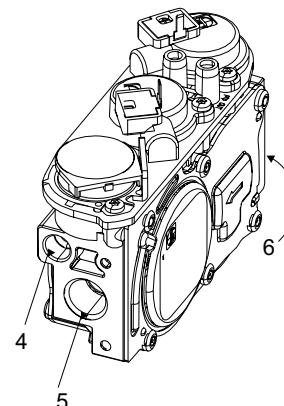
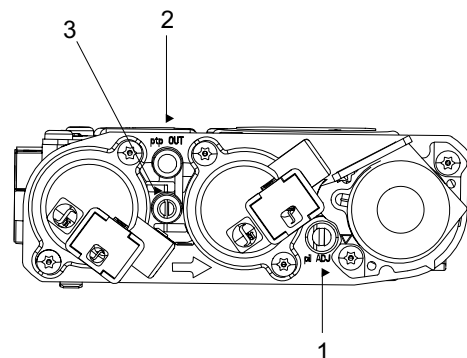

## GAS LINE INSTALLATION

Since some municipalities have additional local codes it is always best to consult with your local authorities and the AS4558 / NZS 5262 installation code & AS/NZS5601 'gas installation code'.

For installations follow local codes and/or in accordance with AS4558 / NZS 5262 & AS/NZS5601 'gas installation code'.

When using copper or flex connectors use only approved fittings. Always provide a union so that gas lines can be easily disconnected for servicing. Flare nuts for copper lines and flex connectors are usually considered to meet this requirement.

**NOTE:** A shutoff / dante valve should be supplied in or near the unit (or as per local codes) for ease of servicing this appliance.

**IMPORTANT:** Always check for gas leaks with a soap and water solution or gas leak detector. Do not use open flame for leak testing.

**WARNING:** Install in accordance to AS/NZS5601 'gas installation code'.

## AERATION ADJUSTMENT

The burner aeration is factory set but may need adjusting due to either the local gas supply or altitude. Open the air shutter for a blue flame or close for a more yellow flame.

**Minimum Air Shutter Opening:**

3.5 mm	NG
16 mm	ULPG

**Note:** Any damage due to carboning resulting from improperly setting the aeration controls is NOT covered under warranty.

# installation

## UNIT ASSEMBLY PRIOR TO INSTALLATION

The 6 standoffs must be correctly positioned and attached before unit is slid into position.

### STANDOFF ASSEMBLY

The standoffs are shipped in a flat position and must be folded into shape and attached.

- 1) Remove the standoffs from the fireplace.
- 2) Take each standoff and bend into the correct shape. Bend up at the bend lines until the screw holes in the standoff and the pre-punched screw holes on the fireplace top line up.
- 3) Attach the standoff securely to the unit with 2 screws per standoff (on opposite corners).

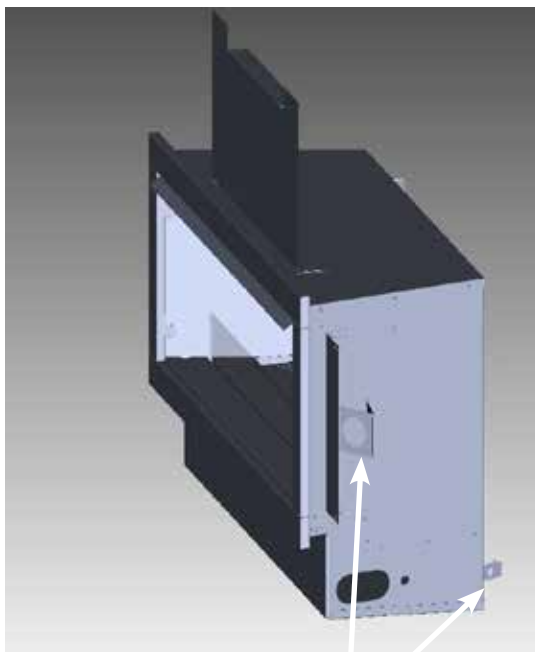
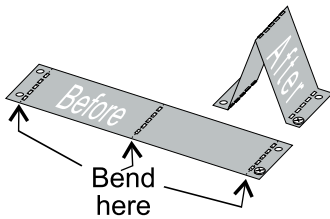

Standoffs installed.

**Note:**

Depending on the material used for finishing, the nailing strips must be set accordingly so that the finished material is always at the 38mm edge of the flange.

### NAILING STRIPS

The nailing strips come attached to the unit. There is 1 plate on each side and 1 on the top that can be folded out as required. Secure the top and side nailing strips to the framing.

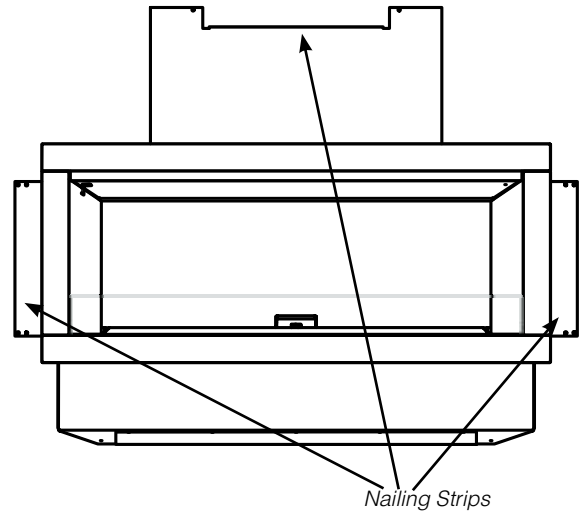

Finished Material	Nailing Strip Position	
13mm	25mm	<p>Nailing Strip 1" Forward (25mm)</p> <p>Unit</p>
25mm	13mm	<p>Nailing Strip 1/2" Forward (13mm)</p> <p>Unit</p>
38mm	0mm(flush)	<p>Nailing Strip Flush w/unit Factory Set</p> <p>Unit</p>



**WALL SWITCH INSTALLATION  
(INCLUDED WITH UNIT)**

- 1) The unit comes with 10' of wire located on the left side of the unit.
- 2) Install supplied electrical box in desired location.
- 3) Route low voltage wire through electrical box.
- 4) Connect 2 wires to switch (use supplied dielectric grease on connections)
- 5) Install weather resistance cover plate to switch using 2 inner holes with screws provided.  
(Ensure gasket and spacer are in place)



- 6) Mount completed switch assembly with cover plate to the electrical box using 2 outer holes on cover plate. (Shown without facing material)



Thermostat Wire Table	
Recommended Maximum Lead Length (Two-Wire) When Using Wall Thermostat (CP-2 System)	
Wire Size	Max. Length
14 GA. (2 mm <sup>2</sup> )	15 m
16 GA. (1.5 mm <sup>2</sup> )	9.5 m
18 GA. (1 mm <sup>2</sup> )	6 m
20 GA. (0.5 mm <sup>2</sup> )	3.5 m

**CAUTION**  
Do not wire millivolt  
wall switch wires  
to 240V wire.

# installation

## WIRING DIAGRAM

This heater does not require a 240V A.C. supply for operation. (Do not cut the ground terminal off under any circumstances.)

**NOTE: 4 AA batteries must be installed in the battery pack to operate the burner switch.**

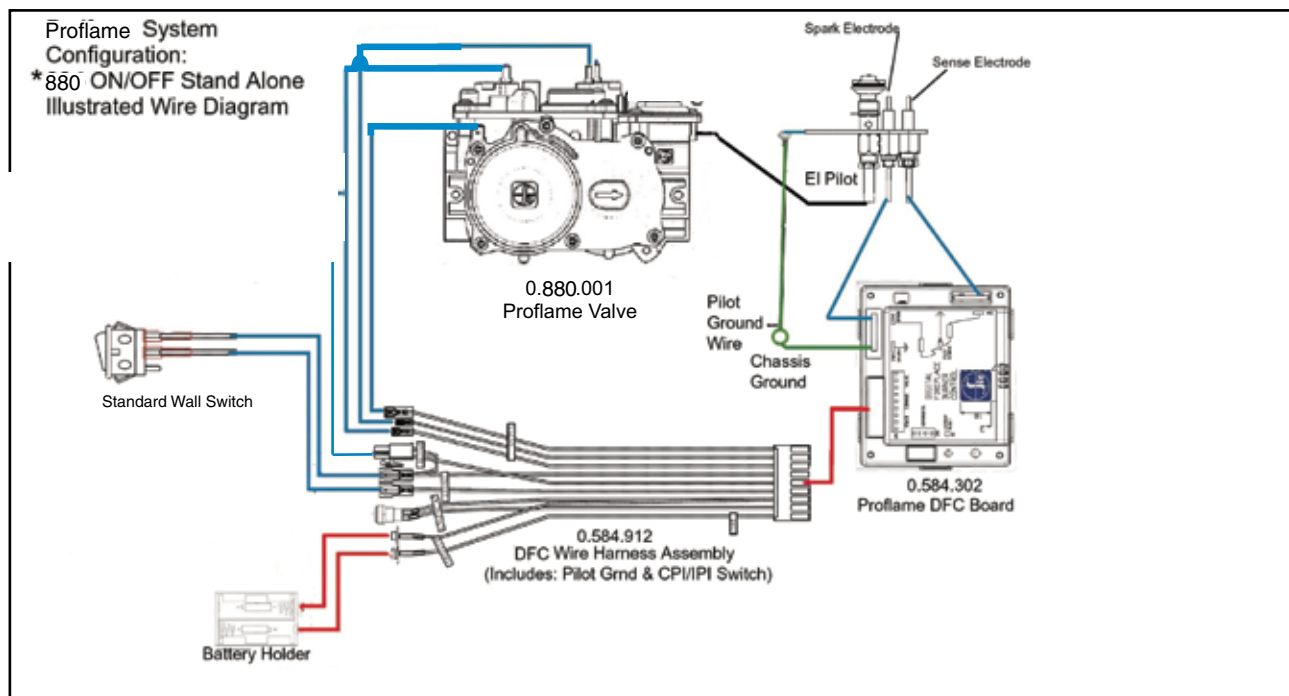

Remove the protective coating from the following components before proceeding. Carefully follow stainless handling instructions on following page.

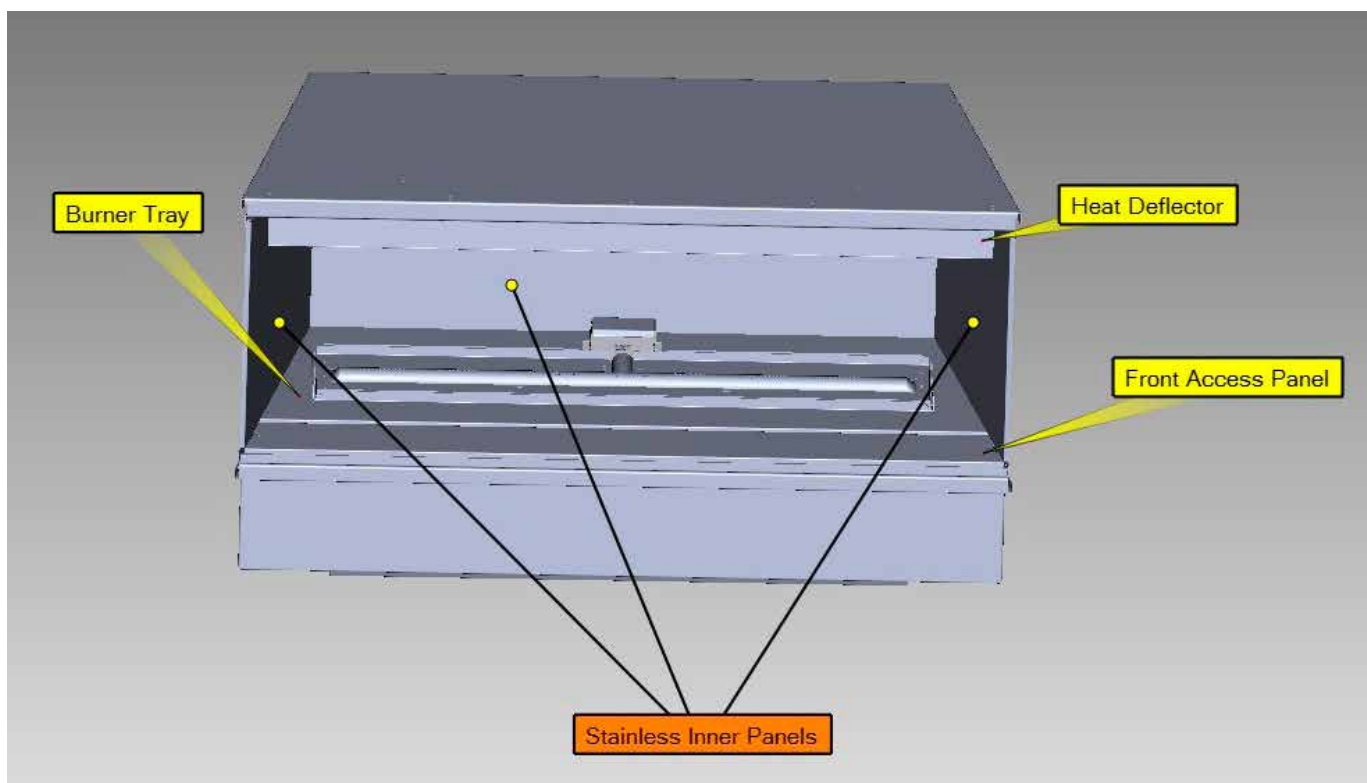

**INNER PANEL INSTALLATION**

<b>Before installation, panels must be handled and cleaned as per instructions noted below:</b>
<b>Stainless Steel Panels</b>
<ul style="list-style-type: none"> <li>Stainless panels must be inspected for scratches and dimples prior to installation. All claims to be recorded at this time. Claims for damage after installation will not receive consideration.</li> </ul>
<ul style="list-style-type: none"> <li><b>To protect the finish during installation and handling</b> - cotton gloves <b>MUST</b> be worn at all times while handling the panels (even when removing protective coating).</li> </ul>
<ul style="list-style-type: none"> <li>Use a hair dryer or similar device to remove the protective coating from the panels.</li> </ul>
<ul style="list-style-type: none"> <li>Stainless panels will discolor a little during normal operation. This is normal and should not be considered a defect.</li> </ul>
<p><b>* All hand and finger marks MUST be cleaned off with a soft cloth and a stainless steel cleaner. Most stainless steel cleaners leave a film/residue on the surface of the panels. Use an ammonia based cleaner (ie. glass cleaner) to remove this film before applying heat to the unit. Failure to do this will result in burn stains on panels which you will be unable to remove. Not protected by product warranty.</b></p>

1) Install the back panel first - to maneuver the panel into position - tilt the top of the panel forward and position the bottom of the panel in first. Use care - do not scratch the panel when clearing the pilot hood.



3) Install other side panel next. Position side panel and secure with a clip and one screw.



2) Install a side panel next (not important which side goes in first). Position the panel with the bend in the panel facing towards the outside or wall of the unit. Position side panel and secure with a clip and one screw.



4) Final install - shown below.

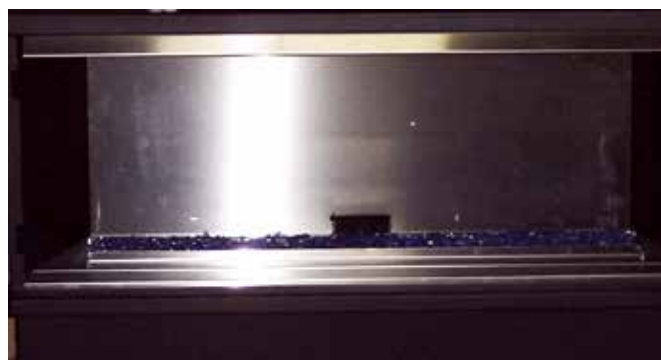

# installation

---

## GLASS CRYSTAL INSTALLATION

Spread the Glass Crystals or Stones evenly over the burner. Ensure the crystals/stones do not overlap excessively as this will affect the flame pattern.

### IMPORTANT NOTE:

Only the approved Glass Crystals and Stones are to be used with these fireplaces. Use of any other type of glass crystals or stones can alter the unit's performance, any damage caused by the use of any unapproved glass or stones will not be covered under warranty.

When using Ceramic Spa/Volcanic Stones **DO NOT** cover burner ports or pilot light that lead to pilot flame.

BURNER PACKAGES		
Unit	Glass Crystals	Stones - Spa / Ceramic / Volcanic
HZO42	1.4 kg	1.4 kg Glass + 35 Volcanic Stones

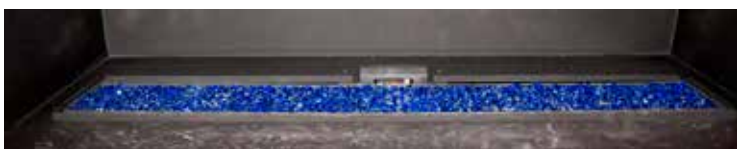

There are 2 optional packages to choose from to cover the firebox base:

- 1) Natural River Pebbles
- 2) Glass Crystals (4 colors available)

Spread the pebbles / crystals evenly on the exposed base of the firebox. Pebbles are **NOT** to be placed anywhere on the burner or over top of the Glass Crystals or optional Stones.

**IMPORTANT NOTE:** Only the supplied and approved pebbles / glass crystals are to be used with these fireplaces. Use of any other type of pebbles, glass crystals or other material can create a danger and will void the warranty.

Firebox (Around Burner) Packages		
Unit	Glass Crystals	Pebbles
HZO42	1.4kg	1 package (3 x bags pebbles)

## VOLCANIC STONE INSTALLATION

Evenly spread the glass crystals and volcanic stones over the burner. Ensure the stones do not overlap too much as this will effect the flame pattern.

**IMPORTANT NOTE:**

Only the supplied approved Volcanic Stones are to be used with these fireplaces. Use of any other type of stones can alter the unit's performance, any damage caused by the use of any unapproved glass or stones will not be covered under warranty.

When using Volcanic Stones DO NOT cover burner ports or pilot light that lead to pilot flame. Ensure the stones do not overlap excessively as this will effect the flame pattern.

OUTDOOR VOLCANIC STONE BURNER PACKAGES			
Unit	Volcanic Stones Ivory/Tan	Volcanic Stones Slate/Grey	White Garden Stones
HZO42/HZO42 (AUS)	35 stones w/3lbs glass	35 volcanic stones w/3lbs glass	50 garden stones w/3lbs glass (AUS Only)
PTO30*/Plateau Series	50 stones w/5lbs glass	50 volcanic stones w/5lbs glass	
PTO60	100 stones w/10lbs glass	100 stones w/10lbs glass	
<b>NOTE:</b> * Basalt Volcanic stones are measured by weight not quantity. Each bag contains 15lbs of stones, however the exact quantity and size will vary. Size varies between 2" - 3".			



*Volcanic Stones + Glass Crystals  
For the PTO30, PTO60  
& Plateau Series only*



*Volcanic Stones Ivory /Tan + Glass Crystals  
For the HZO42 & HZO42AUS  
only*



*Volcanic Stones Slate /Grey + Glass Crystals  
For the HZO42 & HZO42AUS  
only*

# installation

## OPTIONAL LOG SET INSTALLATION

Installation of Reflective Panels must be completed before installing the log set.

Read the instructions below carefully and refer to the images. If the logs are broken do not use the unit until they are replaced. Broken logs can interfere with pilot operation. Install 3lbs of glass crystal on the burner (follow glass crystal instruction sheet) before installing logs.

Improper positioning of the logs may create carbon build-up and can alter the unit's performance which is not covered under warranty.

Log kit # 326-930 contains the following pieces:

<u>Part #</u>	<u>Description</u>
A x 1	Log
B x 1	Log
C x 1	Log
D x 1	Log
E x 1	Log

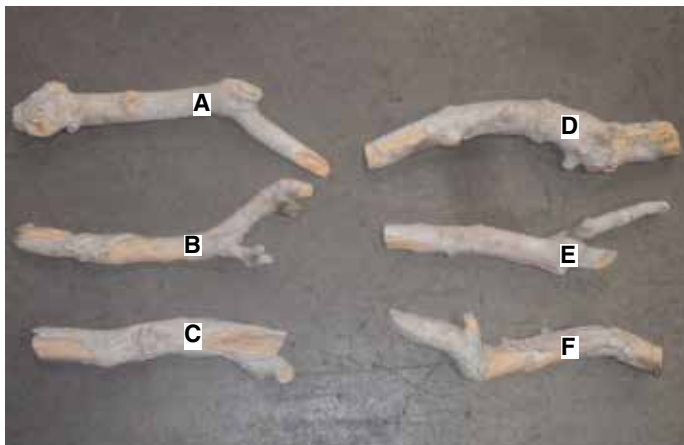

Diagram 1

- 1) Install logs A and C on the burner as shown below. Orient the logs in the same way and in a similar location on the left side of the burner as depicted in Diagram 2.



Diagram 2

- 2) Install log B on the burner as shown below. Orient log B across log A in the same way and in a similar position as depicted in Diagram 3.

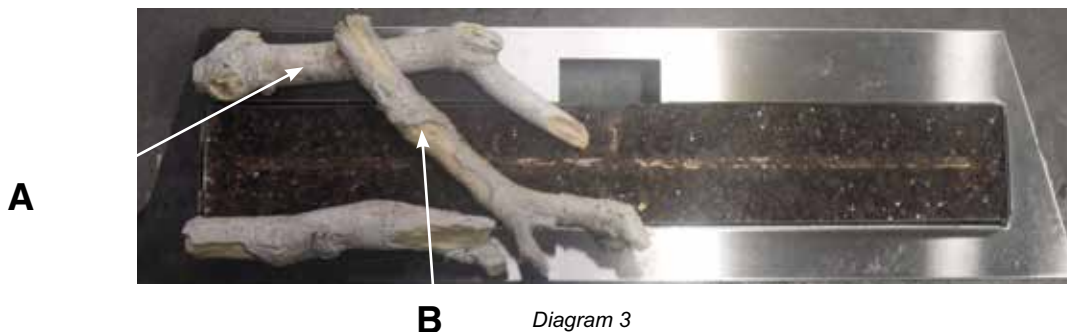

Diagram 3

- 3) Install log E on the right side of the burner as shown below. Orient log E in the same way and in a similar position as depicted in Diagram 4.



Diagram 4

- 4) Install log D on the burner as shown below. Orient log D across log E in the same way and in a similar position as depicted in Diagram 5- log D will rest up against the back panel.



*Diagram 5*

- 5) Install log F on the right side of the burner as shown below. Orient log F in the same way and in a similar position as depicted in Diagram 6.



*Diagram 6*



*Final Install*

# installation

---

## HEAT DEFLECTOR INSTALLATION

1) Install the heat deflector to the top inside of the firebox with 4 screws as shown below.

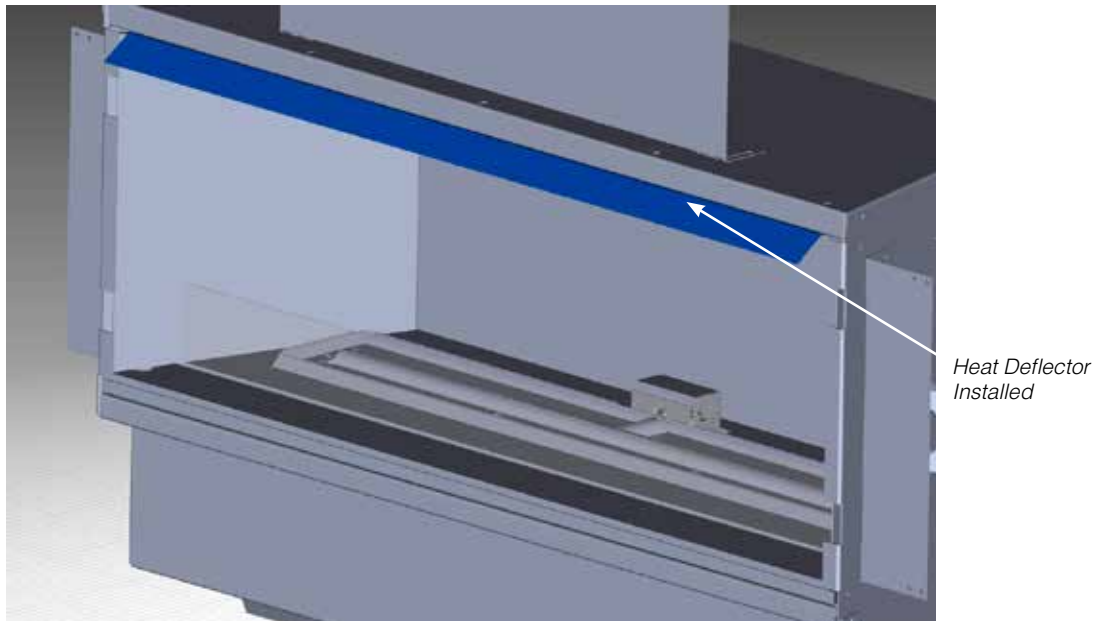
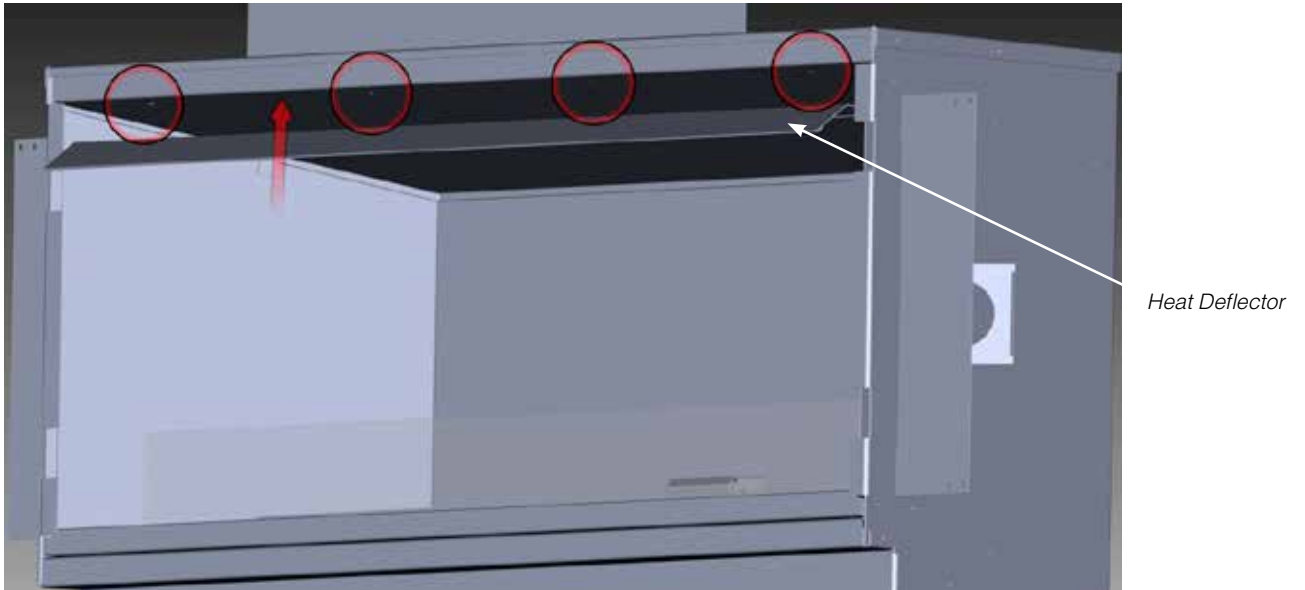



## FACEPLATE INSTALLATION

Remove the protective coating from the faceplate before installation - see handling instructions in panel install section.

- 1) To install the faceplate - line up the tabs on the faceplate with the 'C' shaped openings on the left and right sides of the unit. There are 3 slots on each tab so the faceplate to accommodate different finishing materials.

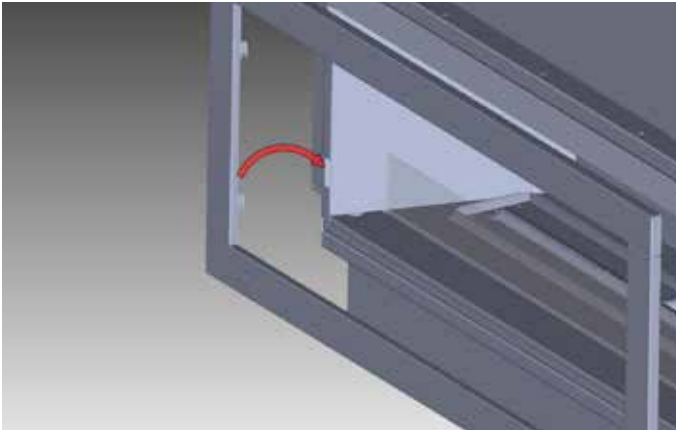

- 3) For installations where thicker finishing material is used - the optional trim piece may be installed to fill the gap. Install the trim in front of the bottom access panel as shown below.

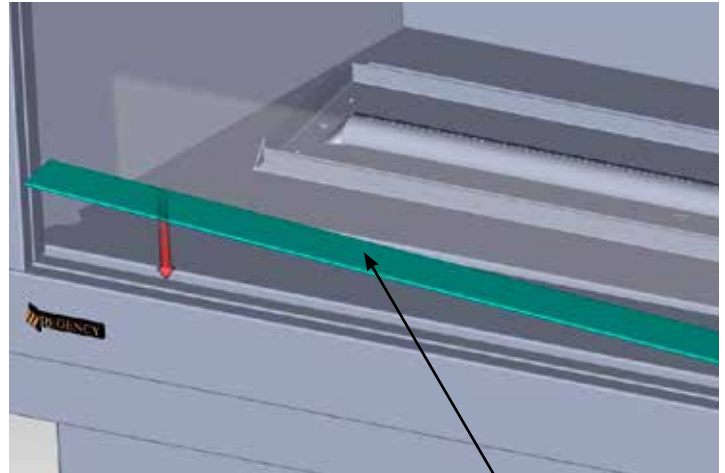

Trim Piece

- 4) To remove - reverse steps.

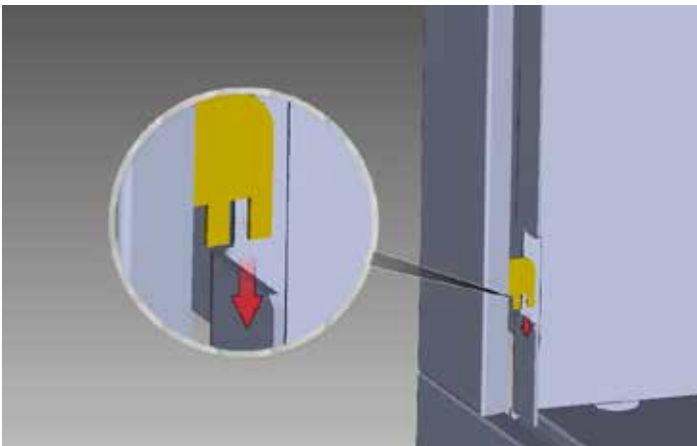

- 2) Install logo onto faceplate.

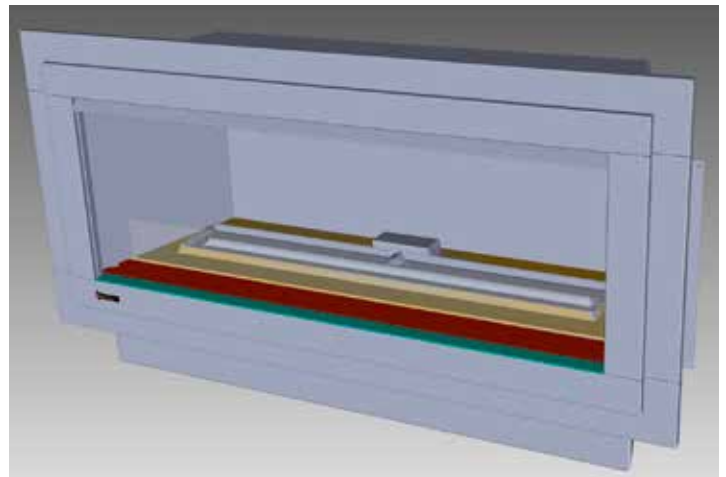

Final Install

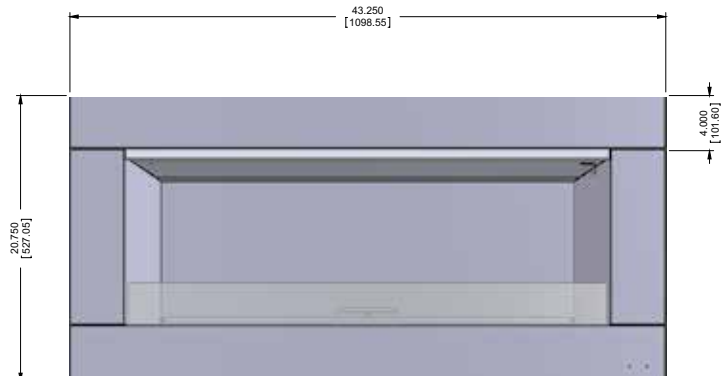
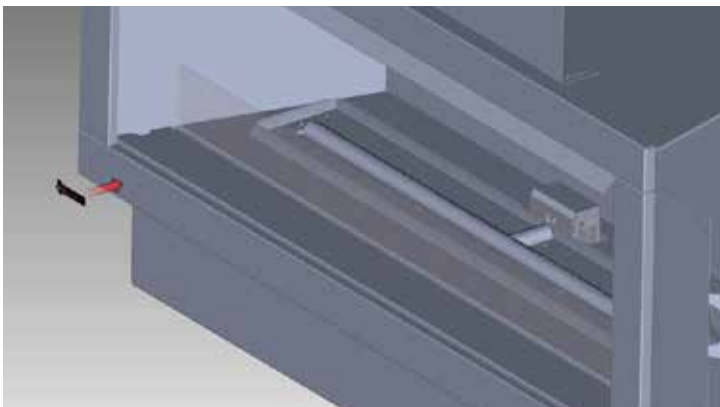

Faceplate Dimensions

# installation

---

## GLASS WIND SHIELD INSTALLATION

- 1) To install the glass wind shield - slot it into the space between the burner tray cover and the bottom access panel.

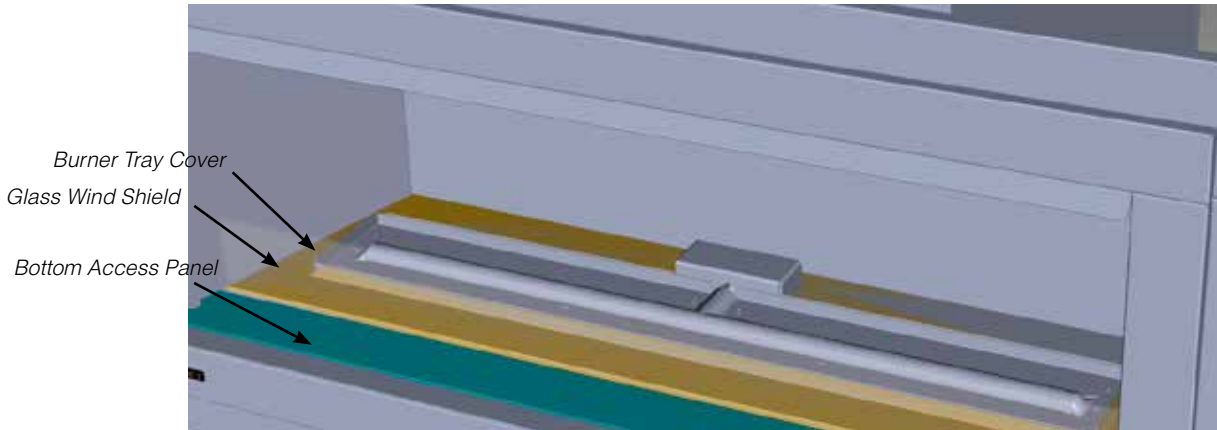

## WEATHER COVER INSTALLATION / REMOVAL

- 1) The unit should be covered when not in use for extended periods of time. The soft fabric cover is made of weather resistant material - to protect the unit from the elements. Starting from one corner - slide the cover over the corner, then stretch the cover until it is fitted over all four corners.



**CAUTION:**  
Never start the unit with the cover on.  
Let the unit cool before installing the cover.  
Turn off gas supply to unit before installing cover.





*Weather Cover Installed*

## ASSEMBLY INSTRUCTIONS FOR A STEEL STUD FRAMING KIT FOR HZO42

Follow these instructions to construct a steel stud frame for the Outdoor fireplace;

Overall dimensions = 70-15/16" (1801mm) W x 20" (508mm) D x 47-5/16" (1201mm) H.

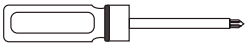
\*\*Non-combustible finishing board not supplied with kit. Board may be purchased at your local hardware/building supply store.

Tools Required	
1 power drill + #2 phillips bit	
1 hand #2 screwdriver (Phillips)	
1 level	
1 tape measure	

326-900 CONTENTS:	
Top / Bottom	(A) 326-079 x 2
Vertical Supports - Tall	(B) 326-080 x 8
Vertical Supports - Short	(C) 326-081 x 6
Midsection	(D) 326-076 x 2
Header	(E) 326-060 x 1
Corner Brace	(F) 326-005 x 2
Vertical support - back	(G) 326-083 x 1
Midsection support	(H) x 2
Wafer Screws	80

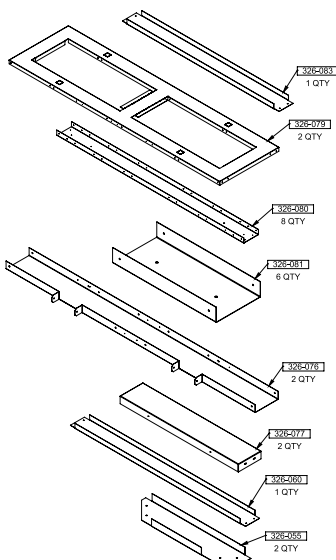
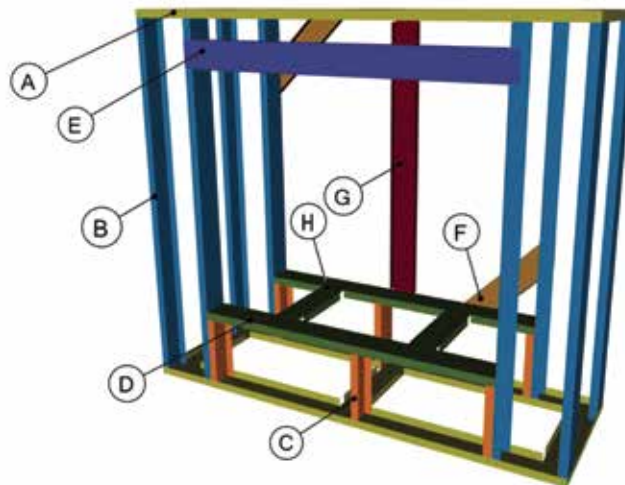

# installation

- 1) Place top/bottom (A) on the ground - flat side down. Bend the tabs up to a 90° angle.

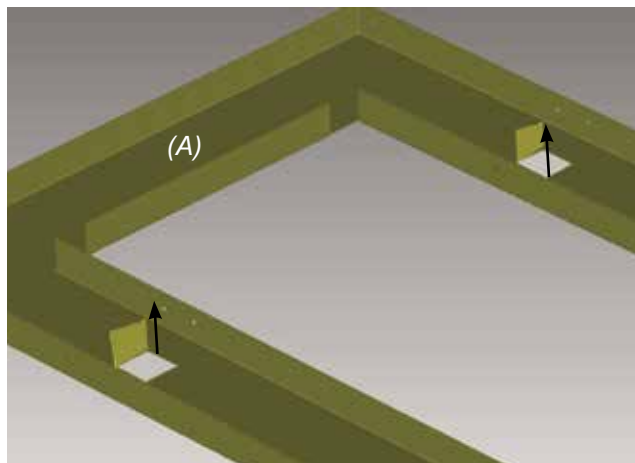

*Bend tabs inward to 90° angle.*

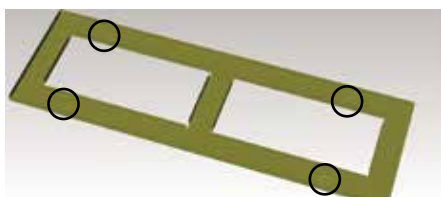

(A)  
*Tab locations*

- 2) Position 4 of the (B) pieces with the flat side of (B) contacting the tab as shown below.

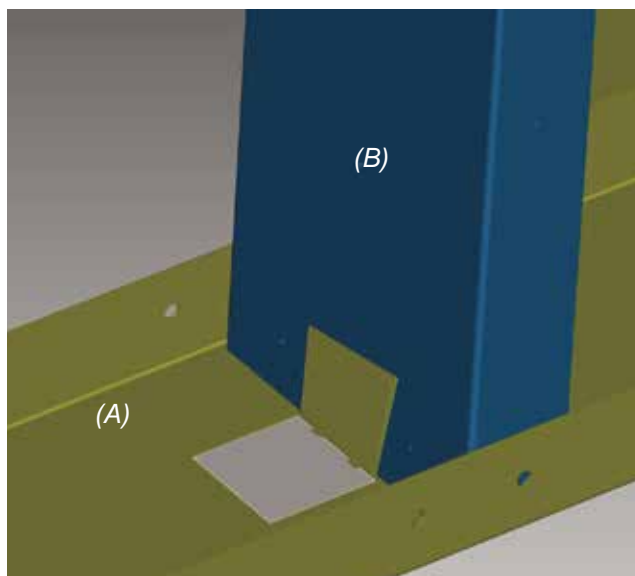

*Part B positioned flat side flush with A tab.*

- 3) Line up the screw holes of (A) with (B). Secure each (B) with 2 wafer screws (one on each side) as shown below.

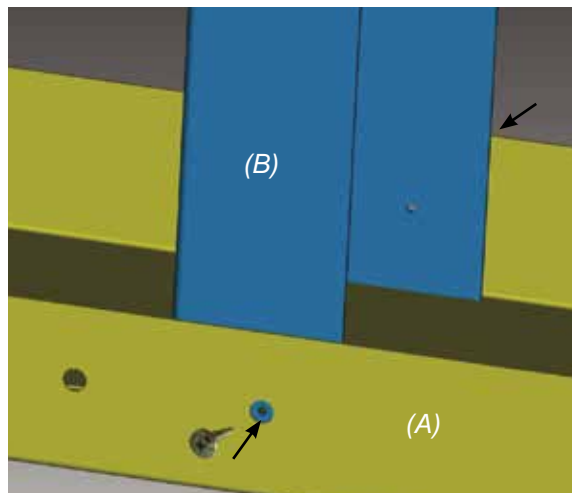

- 4) With all 4 - (B) pieces secured to the bottom with 2 screws (1 on each side) (A) can be placed into position, as shown below. Ensure all tabs on the (A) are bent to 90° and oriented to each (B) as shown in step 2.

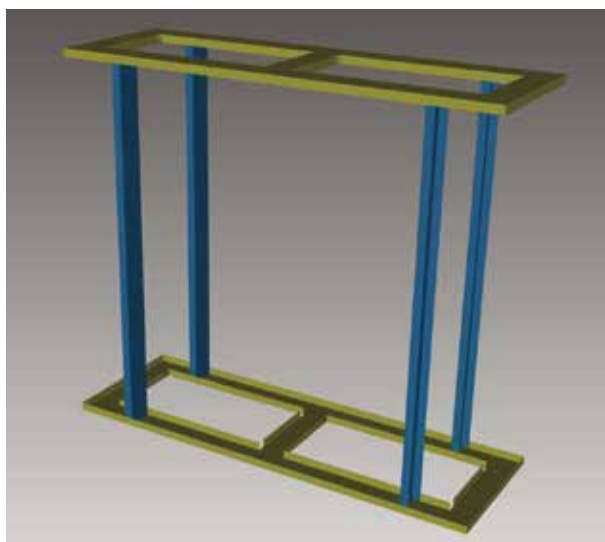

- 5) Line up top (A) screw holes with (B) screw holes and secure with (B) to (A) with 2 wafer screws (1 on each side - 8 in total).

**Note:** Securing inner (B) pieces to top (A) will add rigidity, making it easier to lineup and install outer (B) pieces.

**Important:** (B) - (tall vertical supports) must be positioned as shown to ensure the correct installation of (C).

6) Manoeuvre remaining (B) pieces and position in each corner of the frame - flat side facing out - see 2 diagrams below.

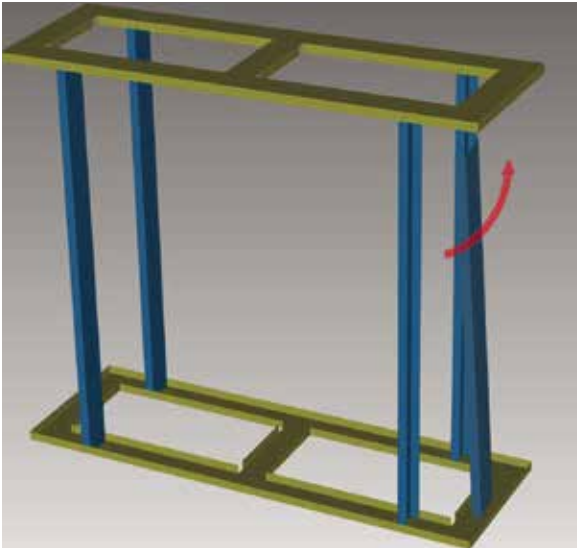

9) Position remaining 2 - (C) pieces offset from center rib as shown below.

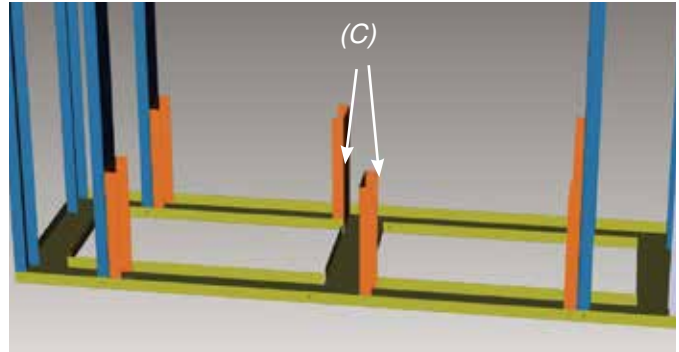

7) Line up screw holes on top / bottom (A) with each (B)- secure with 3 wafer screws each on top and bottom - 6 screws in total for each outer (B) (3 top- 3 bottom).

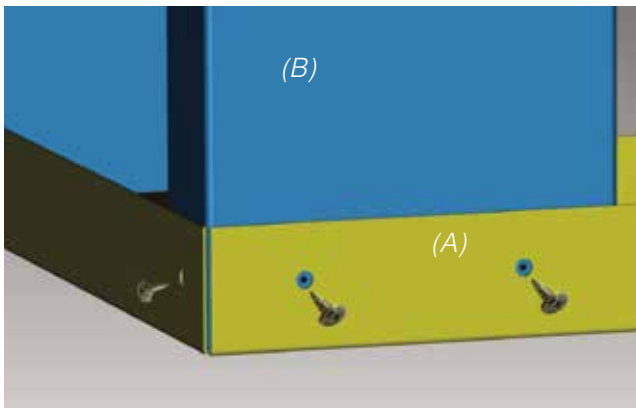

10) Position (D) on top of (C) pieces - line up screw holes and secure (D) to (C) with 12 wafer screws.

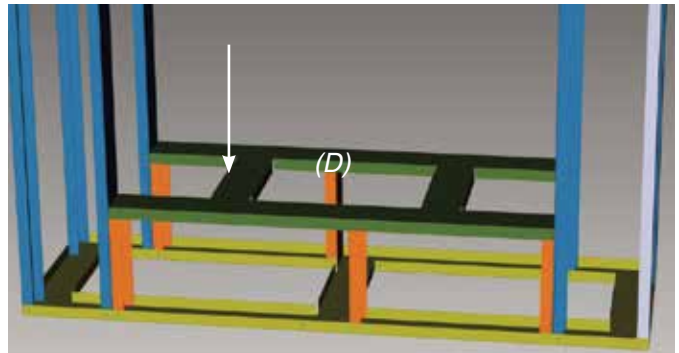

8) Position 4 - (C) pieces with the flat side back to back with the flat side of each inner Part B as shown below. Secure each (C) to bottom (A) with 3 wafer screws (one on each side and one at top as shown below).

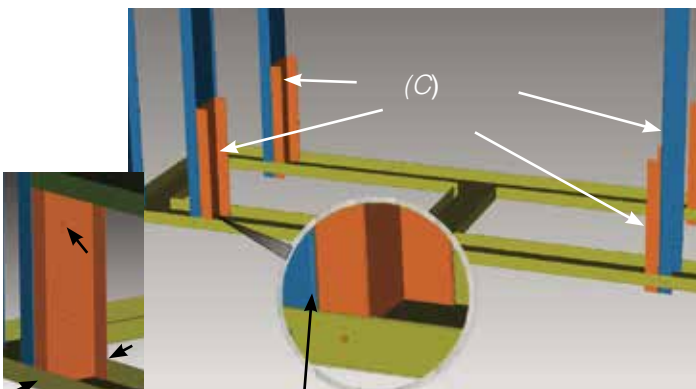

(C)Screw locations

(B)+ (C) - flat sides back to back

11) Measure 1135mm from floor (bottom of the header location) line up (E) (header) with appropriate screw holes.

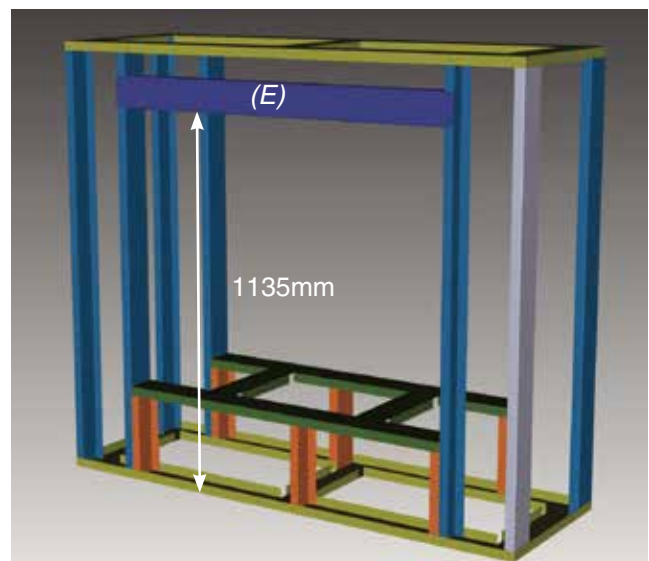

## installation

**12)** Line up screw holes on (E) (header) and (B) (inner vertical support). Secure with 2 wafer screws on each side (4 total) as shown below. This will now be the front of the frame.

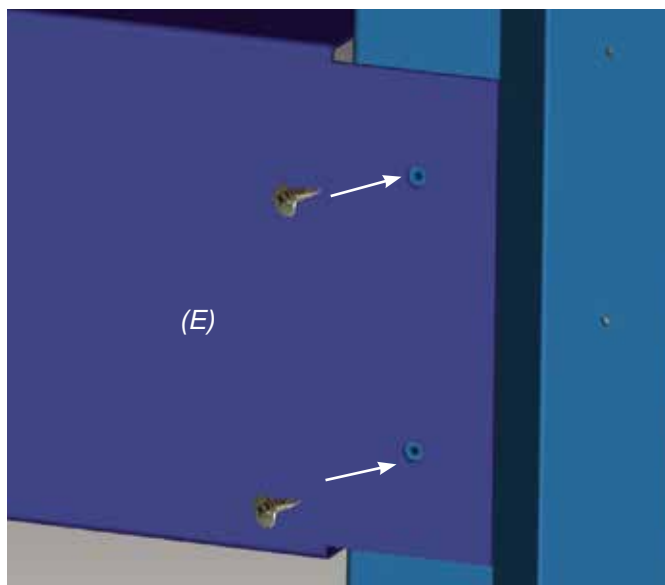

**13)** On the back side of the frame. Install both (F) pieces (corner brace) on opposite corners.

**Important:** (F) parts must be installed opposite from one another for rigidity as shown below.

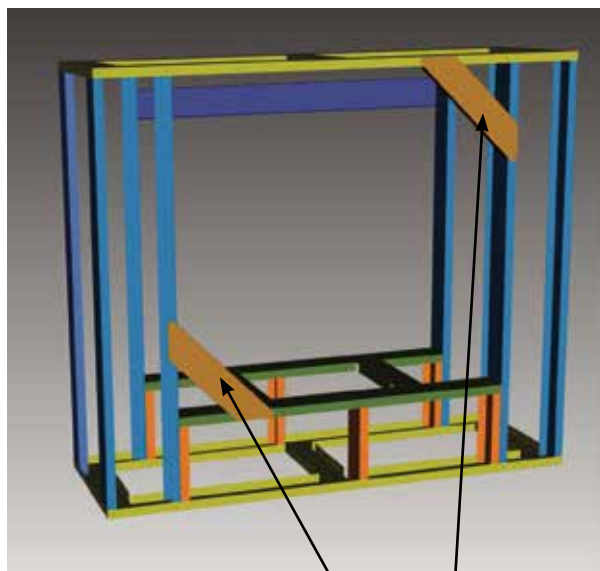

(F) corner brackets positioned in opposite corners

**14)** Line screw holes on 1 (F) (corner brace) with (B) + (A) and secure with 4 wafer screws. as shown below.

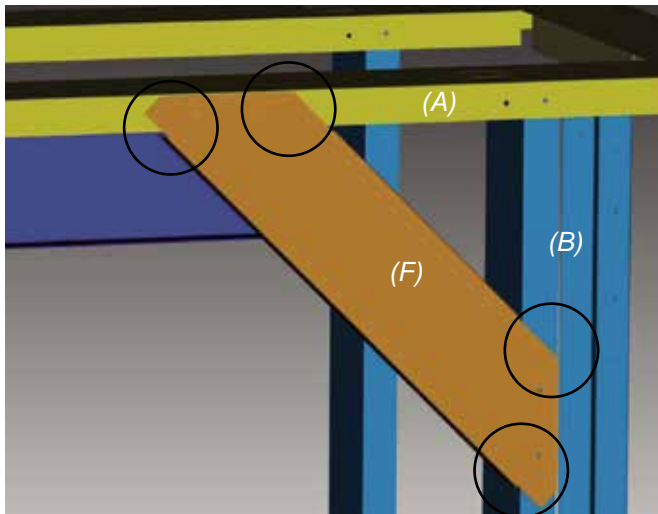

**15)** Repeat step 14 for opposite corner as shown below.

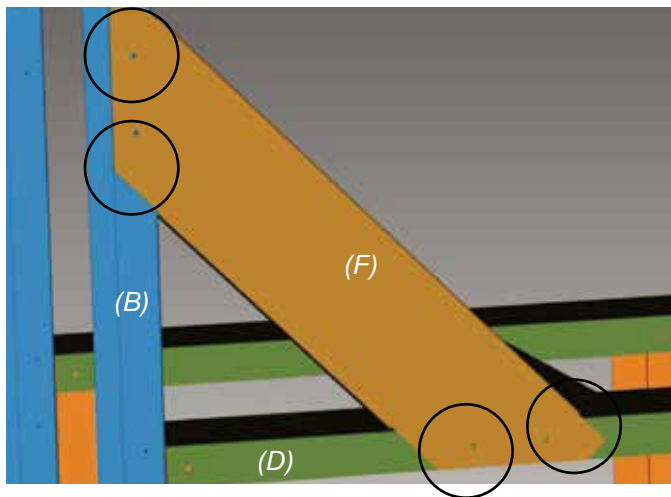

**16)** Install vertical back support to back of assembly with 2 screws at top and bottom in locations shown below.

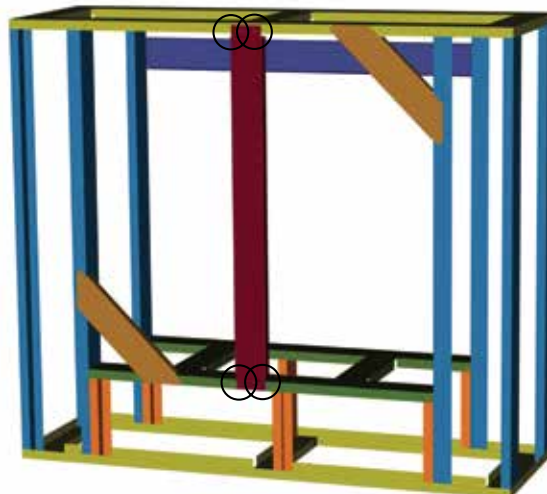

**Note:** Confirm assembly is level and square before proceeding with further materials.

## REMOTE PROPANE / ULPG GAS ENCLOSURES INSTALLATION GUIDELINES

If the unit is permanently connected to a gas piping system from a remote supply tank, installation must be in accordance with local codes or, in absence of local codes, with the AS/ NZS5601 'Gas Installation Code'.

If constructing an enclosure to conceal the propane / ULPG cylinder- the enclosure **must adhere** to the following construction requirements:

Enclosures may be constructed with one side completely open **OR** if the enclosure is built with four (4) sides, a top and a bottom:

- A Propane / ULPG gas cylinder enclosure requires four (4) ventilation openings at the top and bottom of the enclosure. The openings must adhere to the minimum requirements according to the capacity of the cylinder (see Diagram 1).
- Each opening in the enclosure must be equally sized and spaced at a minimum of 180°. Openings must remain unobstructed.
- Top ventilation openings are required on the side walls of the enclosure within 5" (127mm) of the top of the enclosure. They need to be of equal size, unobstructed and spaced 180° apart. Ventilation openings shall have a total free area at high level of NOT less than 10,000 mm<sup>2</sup>.

- Bottom opening have a total free area of NOT less than 6000 mm<sup>2</sup> or consist of perforations with a total free area of NOT less than 25% of the sidewall area (see example below).
- Every opening must have minimum dimensions to allow entrance of a 1/8" (3.2mm) diameter rod.
- Ventilation openings in side walls must not communicate directly with other enclosures of the appliance.
- The cylinder valve must be easily accessible by hand. Connections should be easy to leak test inside the enclosure. A door on the enclosure is acceptable only if easily opened without the use of tools and is non locking.
- The enclosure needs to isolate the cylinder from the burner compartment and provide protection from radiation, act as a flame barrier and protect the cylinder from foreign material.
- The enclosure needs to allow connection, disconnection and inspection of the connection of the ULPG - gas cylinder.
- The enclosure should allow testing of any connection on the ULPG cylinder that might be disturbed during installation.
- All flexible connections and hoses must be kept out of pathways or areas where hose may be subject to accidental damage.

Propane/ULPG Tank Enclosure Specifications	
A	Opening 180° apart from each other
B	Minimum of 2" (50.8mm) from floor/ground to base of tank
C	Maximum of 1" (25.4mm) from to base of tank to bottom of opening

**WARNING: When connecting or disconnecting, leak test connection with soapy water.**

**WARNING: 'LIMITED FLEXIBILITY CONNECTORS MUST COMPLY WITH AS 4631'.**

**WARNING: Hose assemblies must comply with AS/ NZS1869 & Australian standards.**

**WARNING: Keep all hoses and materials away from appliance as it will be subjected to radiant heat and could be seriously damaged.**

**WARNING: Inspect all hoses and if there is evidence of excessive damage, it shall be replaced. Inspect all hoses prior to use.**

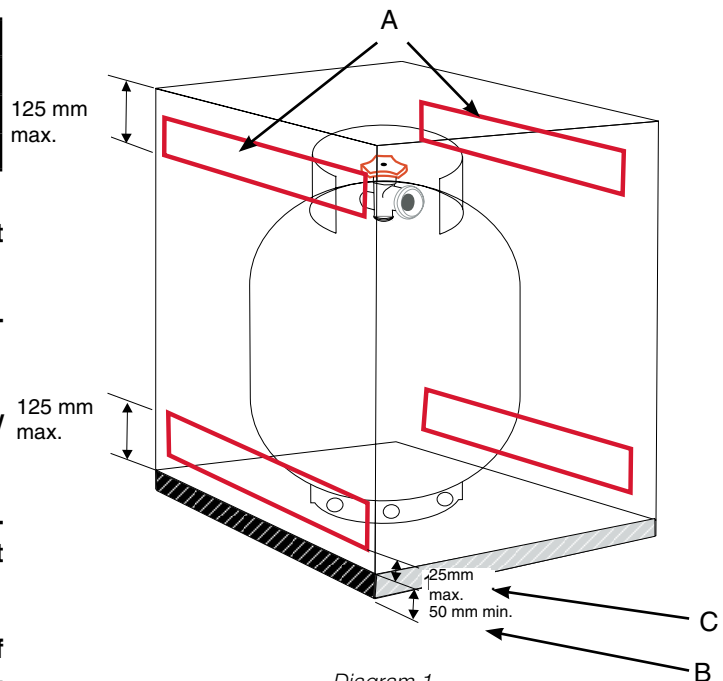

Diagram 1

# operating instructions

---

## OPERATING INSTRUCTIONS

- 1) Read and understand these instructions before operating this appliance.
- 2) Check to see that all wiring is correct and enclosed to prevent possible shock.
- 3) Check to ensure there are no gas leaks.
- 4) Ensure that the stainless panels are installed.
- 5) Verify log placement. If the pilot cannot be seen when lighting the unit, the logs have been incorrectly positioned.
- 6) The unit should never be turned off, and on again without a minimum of a 60 second wait.

---

## LIGHTING PROCEDURE

- 1) Turn on ON/OFF switch.
- 2) Press and release on ON/OFF button once.
- 3) After approximately 4 seconds the spark ignition system will spark for 60 seconds to light the main burner.
- 4) The unit will turn on.

**Note:** The first try for ignition will last approximately 60 seconds. If there is no flame ignition (rectification) the board will stop sparking for approximately 35 seconds. After wait time, the board will start second try for ignition by sparking for approximately 60 seconds. If there is still no positive ignition the board will go into lock out.

The system will need to be reset as follows:

- a) Turn the system off using ON/OFF switch.
- b) After approximately 2 seconds turn on ON/OFF switch.
- c) Unit will repeat step 2.

---

## SHUTDOWN PROCEDURE

- 1) Turn ON/OFF switch.
- 2) If service is to be performed - you must disconnect the battery pack.

## FIRST FIRE

The first fire in your fireplace is part of the paint curing process. To ensure that the paint is properly cured, it is recommended that you burn your fireplace for at least four (4) hours the first time you use it.

When first operated, the unit will release an odour caused by the curing of the paint, the burning off of any oils remaining from manufacturing.

The glass panel may require cleaning after the unit has cooled down.

## DO NOT ATTEMPT TO CLEAN THE GLASS WHILE IT IS HOT.

**Note:** When the glass is cold and the appliance is lit, it may cause condensation and fog the glass. This condensation is normal and will disappear in a few minutes as the glass heats up.



# COPY OF LIGHTING PLATE INSTRUCTIONS

The lighting plate is located on the underside of the front access panel in the unit.

<p><b>FOR YOUR SAFETY READ BEFORE LIGHTING</b></p> <p>If you do not read and understand these instructions completely before you attempt to operate this fireplace, serious or fatal injuries could result from improper installation, adjustment, alteration, service or repair. Hot surfaces will be very hot. Always use proper care and precautions. Failure to heed the warnings or follow the instructions could result in property damage, injury or death. For additional information consult a qualified installer, service agency or the gas supplier.</p> <p><b>NEVER</b> use the fireplace if you have a gas odor which you cannot identify as coming from a gas appliance. If you cannot reach your gas supplier, call the fire department.</p> <p><b>NE PAS TOUJOURS S'ENFUMER.</b> Ne pas tenter d'allumer le feu sans avoir vérifié manuellement l'absence de gaz. Si vous sentez une odeur de gaz, appelez immédiatement votre fournisseur de gaz. Si vous ne pouvez pas rejoindre le fournisseur de gaz, appelez le service incendies.</p> <p><b>NE SAISIEZ PAS LE FEU.</b> Ne tentez pas d'allumer le feu sans avoir vérifié manuellement l'absence de gaz. Si vous sentez une odeur de gaz, appelez immédiatement votre fournisseur de gaz. Si vous ne pouvez pas rejoindre le fournisseur de gaz, appelez le service incendies.</p>	<p><b>CAUTION -</b> Hot white in operation. Do not touch. Burns may result. Due to high surface temperature, gas line, furniture, gasoline, oil, etc., do not use any flammable liquids or vapors nearby. Keep away from children. See installation instructions for proper use.</p> <p><b>ATTENTION -</b> Hot white in operation. Do not touch. Burns may result. Due to high surface temperature, gas line, furniture, gasoline, oil, etc., do not use any flammable liquids or vapors nearby. Keep away from children. See installation instructions for proper use.</p>	<p><b>TO TURN OFF GAS APPLIANCE</b></p> <p>Turn off ON/OFF switch if service is to be performed - refer to manual for instructions.</p> <p>Appuyer sur le bouton ON / OFF. Fonction de l'appareil, voir le manuel d'instruction pour plus de détails.</p> <p><b>DO NOT REMOVE THIS INSTRUCTION PLATE</b></p>
<p><b>WHAT TO DO IF YOU SMELL GAS</b></p> <ul style="list-style-type: none"> <li>Do not try to light any appliance.</li> <li>Do not try to light the pilot by hand.</li> <li>Do not touch the burner control.</li> <li>Immediately call your gas supplier from a neighbour's phone. Follow the gas supplier's instructions.</li> <li>If you cannot reach your gas supplier, call the fire department.</li> <li>No part tenter d'allumer le feu sans avoir vérifié manuellement l'absence de gaz.</li> <li>Ne pas tenter d'allumer le feu sans avoir vérifié manuellement l'absence de gaz.</li> <li>Ne touchez à aucun interrupteur; n'utilisez pas de téléphones se trouvant dans le bâtiment.</li> <li>Ne touchez à aucun interrupteur; n'utilisez pas de téléphones se trouvant dans le bâtiment.</li> </ul> <p><b>AVANT DE FAIRE FONCTIONNER L'APPAREIL</b>, remplir autour de l'appareil pour décider si vous sentez une odeur de gaz. Si vous sentez une odeur de gaz, appelez immédiatement votre fournisseur de gaz. Si vous ne pouvez pas rejoindre le fournisseur de gaz, appelez le service incendies.</p> <p><b>QUE FAIRE SI VOUS SENTEZ UNE ODEUR DE GAZ :</b></p> <ul style="list-style-type: none"> <li>Ne pas essayer d'allumer l'appareil.</li> <li>Ne pas essayer d'allumer le feu à la main.</li> <li>Ne pas toucher les commandes de l'appareil.</li> <li>Appeler immédiatement votre fournisseur de gaz. Suivez les instructions de votre fournisseur de gaz.</li> <li>Si vous ne pouvez pas joindre votre fournisseur de gaz, appelez le service incendies.</li> </ul>	<p><b>LIGHTING INSTRUCTIONS</b></p> <p>STOP! Read the safety information on this label.</p> <ol style="list-style-type: none"> <li>Turn ON/OFF switch to OFF.</li> <li>After approximately 4 seconds the spark ignition system will spark.</li> <li>The unit will turn on.</li> </ol> <p>Note: The first attempt to ignition will last approximately 60 seconds. If the unit does not ignite after the first attempt, wait approximately 35 seconds. After this wait time, the board will start a second try for ignition by sparking for approximately 60 seconds. If the unit does not ignite after the second attempt the board will go into lock out. The system will need to be reset as follows (after going into lock out):</p> <ol style="list-style-type: none"> <li>Wait 5 minutes - turn the system off using ON/OFF switch.</li> <li>After approximately 2 seconds turn on ON/OFF switch.</li> <li>Unit will repeat step 2.</li> </ol>	<p>1) Appuyer sur l'interrupteur ON / OFF des étincelles pendant 60 secondes afin d'amorcer le système. Les flammes s'allumeront.</p> <p>Remarque : Au premier allumage, le système entre en mode de démarrage pendant environ 60 secondes. Si le système n'allume pas, attendez environ 35 secondes. C'est ce qu'on appelle l'étape de réinitialisation. Le système tentera une deuxième tentative de démarrage pendant 60 secondes. Si les flammes ne s'allument toujours pas, le système entrera en mode de verrouillage. Le système devra être réinitialisé en suivant les étapes ci-dessous (pour le déverrouiller) :</p> <ol style="list-style-type: none"> <li>Attendez 2 secondes et rallumez le système en réglant l'interrupteur sur OFF.</li> <li>L'unité répétera l'étape 2.</li> </ol>

## MAINTENANCE INSTRUCTIONS

- 1) Always turn off the gas valve and unplug the batteries before cleaning. For relighting, refer to lighting instructions. Keep the burner and control compartment clean by brushing and vacuuming at least once a year. When cleaning the logs, use a soft clean paint brush as the logs are fragile and easily damaged.
- 2) Clean appliance with a damp cloth (never when unit is hot). Never use an abrasive cleaner. The glass should be cleaned with a gas fireplace glass cleaner.
- 3) Hand and finger marks should be cleaned off with a soft cloth and a stainless steel cleaner. Most stainless steel cleaners leave a film / residue on the surface of the panels. Use an ammonia based cleaner (ie. glass cleaner) to remove this film before applying heat to the unit. Failure to do this will result in burn stains on panels which you will be unable to remove.
- 4) The heater is finished in a heat resistant paint and should only be refinished with heat resistant paint. Regency® uses StoveBright Paint - Metallic Black #6309.
- 5) Make a periodic check of burner for proper position and condition. Visually check the flame of the burner periodically, making sure the flames are steady; not lifting or floating. If there is a problem, call a qualified service person.
- 6) The appliance must be inspected before use, and at least annually, by a qualified field service person, to ensure that the flow of combustion and ventilation air is not obstructed.
- 7) Do not use this appliance if any part has been under water. Immediately call a qualified service technician to inspect the appliance and to replace any part of the control system and any gas control which has been under water. This is not covered under the terms of the warranty policy.
- 9) Verify operation after servicing.

**YOUNG CHILDREN SHOULD BE CAREFULLY SUPERVISED WHEN THEY ARE IN THE SAME AREA AS THE APPLIANCE. TODDLERS, YOUNG CHILDREN AND OTHERS MAY BE SUSCEPTIBLE TO ACCIDENTAL CONTACT BURNS. A PHYSICAL BARRIERS IS RECOMMENDED IF THERE ARE AT RISK INDIVIDUAL IN THE HOUSE. TO RESTRICT ACCESS TO A FIREPLACE OR STOVE, INSTALL AN ADJUSTABLE SAFETY GATE TO KEEP TODDLERS, YOUNG CHILDREN AND OTHER AT RISK INDIVIDUALS OUT OF THE ROOM AND AWAY FROM HOT SURFACES.**

**CHILDREN AND ADULTS SHOULD BE ALERTED TO THE HAZARDS OF HIGH SURFACE TEMPERATURES, ESPECIALLY THE FIREPLACE GLASS AND FACEPLATE, AND SHOULD STAY AWAY TO AVOID BURNS OR CLOTHING IGNITION.**

**CLOTHING OR OTHER FLAMMABLE MATERIAL SHOULD NOT BE PLACED ON OR NEAR THE APPLIANCE.**

**ANY PROTECTIVE DEVICE REMOVED FOR SERVICING, SHALL BE REPLACED PRIOR TO OPERATING THE APPLIANCE.**

**INSTALLATION OF APPLIANCES FITTED TO FIXED GAS SUPPLY SYSTEMS AND REPAIR OF ALL APPLIANCES MUST BE CARRIED OUT BY A QUALIFIED SERVICE PERSON.**

## VALVE ASSEMBLY REPLACEMENT

- 1) Turn the unit off and allow it to cool down to room temperature.
- 2) Turn off the gas supply to the unit.
- 3) Remove trim.

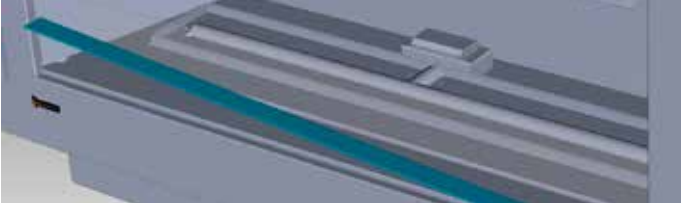

- 4) Remove the faceplate by lifting it up and off the unit.

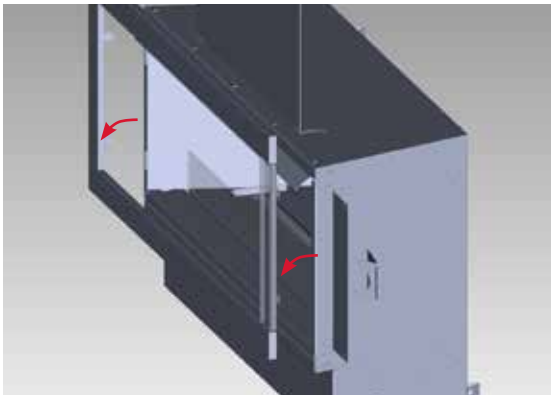

- 5) Remove the glass wind shield by lifting it up and out- place on a soft surface.

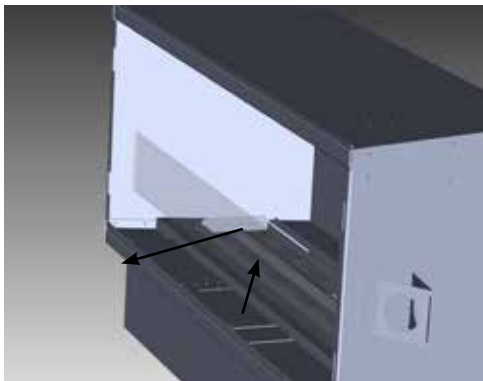

- 6) Remove the screw and panel clip on the right side. Remove the right side panel once the clip has been removed.



- 7) Remove the screw and panel clip on the left side. Remove the left side panel once the clip has been removed.

- 8) Remove the back panel once the 2 side panels have been removed.

- 9) Remove the front access panel by lifting up and out.



- 10) Remove the burner tray by lifting up and out.

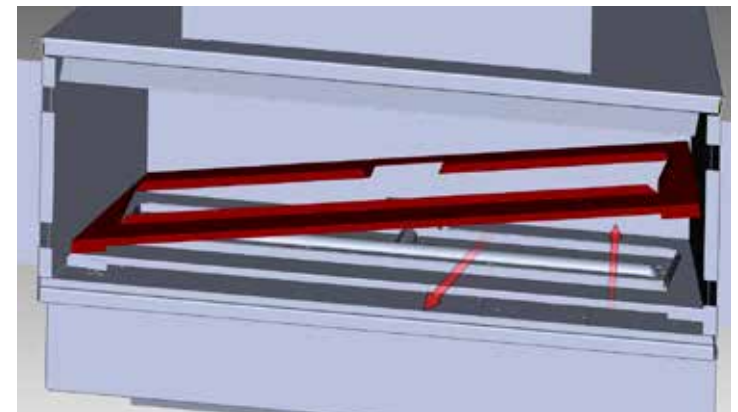

- 11) Remove left and right screws from the burner legs.



# maintenance

12) Slide the burner to the right and lift up and out of the firebox.



13) Remove the 5 screws securing the Digital Fireplace Burner Control to the firebox.



14) Remove the DFBC from the unit - see page 37.

15) Remove 6 screws and lift out valve tray.



16) Replace with new valve tray and reverse steps. Inspect gasket condition, replace if necessary.

## BATTERY REPLACEMENT

1) Remove the 2 screws securing the battery compartment.



2) Lift the battery compartment upwards.



3) Install 4 - AA batteries and reverse steps.

## DIGITAL FIREPLACE BURNER CONTROL REMOVAL

- 1) To access to the Digital firebox burner control box - follow steps 1-11 from the Valve assembly replacement instructions on pages 35,36.
- 2) Disconnect the Black Pilot sensor wire with Red Spade connector from the 'ON' on DFBC (Digital fireplace burner control) box. See Diagram 1 below.
- 5) Disconnect the yellow ground wire with green diagonal stripe for pilot (CN2). See Diagram 4 below.

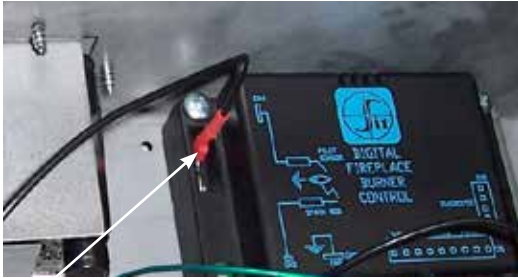

Pilot Sensor Wire

Diagram 1

- 3) Disconnect the Black sparker wire with black spade connector from CN3. See Diagram 2 below.

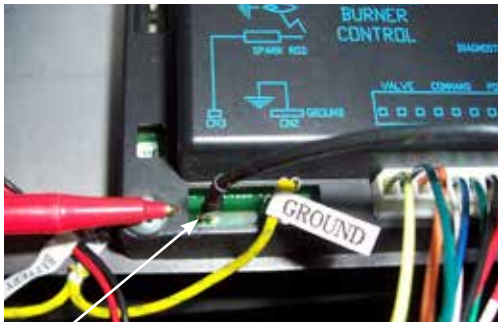

Sparker Wire

Diagram 2

- 4) Disconnect the white and green On/Off switch wires. See Diagram 3 below.

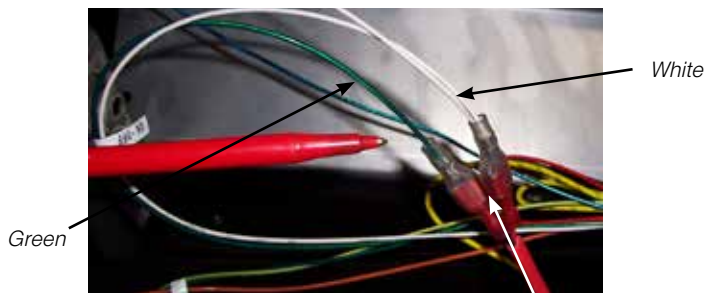
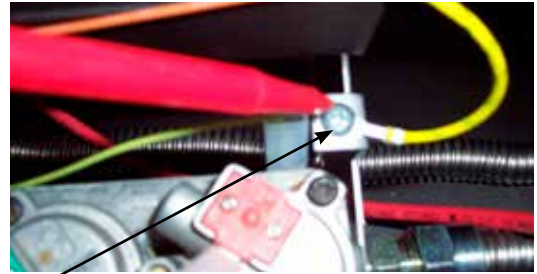

Diagram 3

ON/OFF Wires



Ground Wire

Diagram 4

- 6) Disconnect the three valve wires (yellow wire with green stripe). See Diagram 5 below.

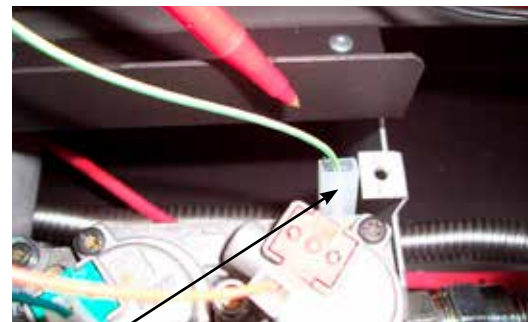

Valve Wire

Diagram 5

## GAS MAINTENANCE - RECOMMENDED ANNUAL ROUTINE

---

In order for your Regency appliance to continue to provide comfort to your home periodic maintenance must be performed to ensure it is operating at peak efficiency. The items in the list should be checked by a licensed gas service technician during the annual service check. Your unit may require more frequent maintenance checks if you notice any changes in how it operates. Operational changes to look for can include, but are not limited to, extended start up time, increased fan noise, residue/carbon build up, white build up on the glass/firebox, increased operating noise etc. Should any of these or other conditions arise, discontinue use and schedule a service check with your local licensed gas technician. The list below shows items your licensed service technician will need to check and service at least annually.

### Clean

- Glass
- Interior bricks / panels
- Burner ports & burner air shutter
- Fan blades
- Log set
- Pilot orifices
- Pilot hood (change as needed)
- Flame sensor (electronic ignition models)
- Flame electrode
- Burner orifice
- Thermocouple (millivolt models)
- Thermopile (millivolt models)

### Inspect

- Pilot assembly
- Burner
- Pressure relief gaskets/doors
- Flue connector gasket if present
- Door seal
- Firebox
- Venting
- Batteries (remote handheld, remote receiver, DC sparker, change as needed)
- Burner media (change as needed)
- Air shutter setting
- Wiring

### Check

- Voltage on thermocouple/thermopile (millivolt models)
- Ohms reading on flame sense (electronic ignition models)
- Inlet/outlet fuel pressures as per rating plate
- Voltage/ohms readings on gas valve
- Ohms reading to on/off switch circuit (Millivolt models)

### Gas Leak Tests

- Check main gas line connection to valve
- Check shut off valve connections
- Check connection at gas valve outlet
- Check connection at main burner orifice
- Check pilot fuel line at valve and at pilot assembly

**MAIN ASSEMBLY**

Part #	Description		
		326-028	Pilot Hood
		326-036	Top nailing strip
		326-037F	Side nailing strip
1) 326-554	Faceplate Assembly		
2) 326-072	Heat Deflector	948-223	Logo Plate
3) 940-368/P	Wind Shield	326-073	Weather Cover
4) 326-525	Burner Assembly NG/LPG/ULPG	911-976	Digital Fireplace Burner Control
		911-012	DFC Ignition Board
5) 904-777	Orifice # 29 (NG)	911-013	Wiring Harness
904-434	Orifice # 47 (LPG/ULPG)		
6) 326-574/P	Valve Assembly NG	918-976	Manual
326-576/P	Valve Assembly Propane/ULPG		
7) 326-007/P	Front access panel		
8) 326-008	Burner Tray Cover		
9) 326-066	Trim Lip		

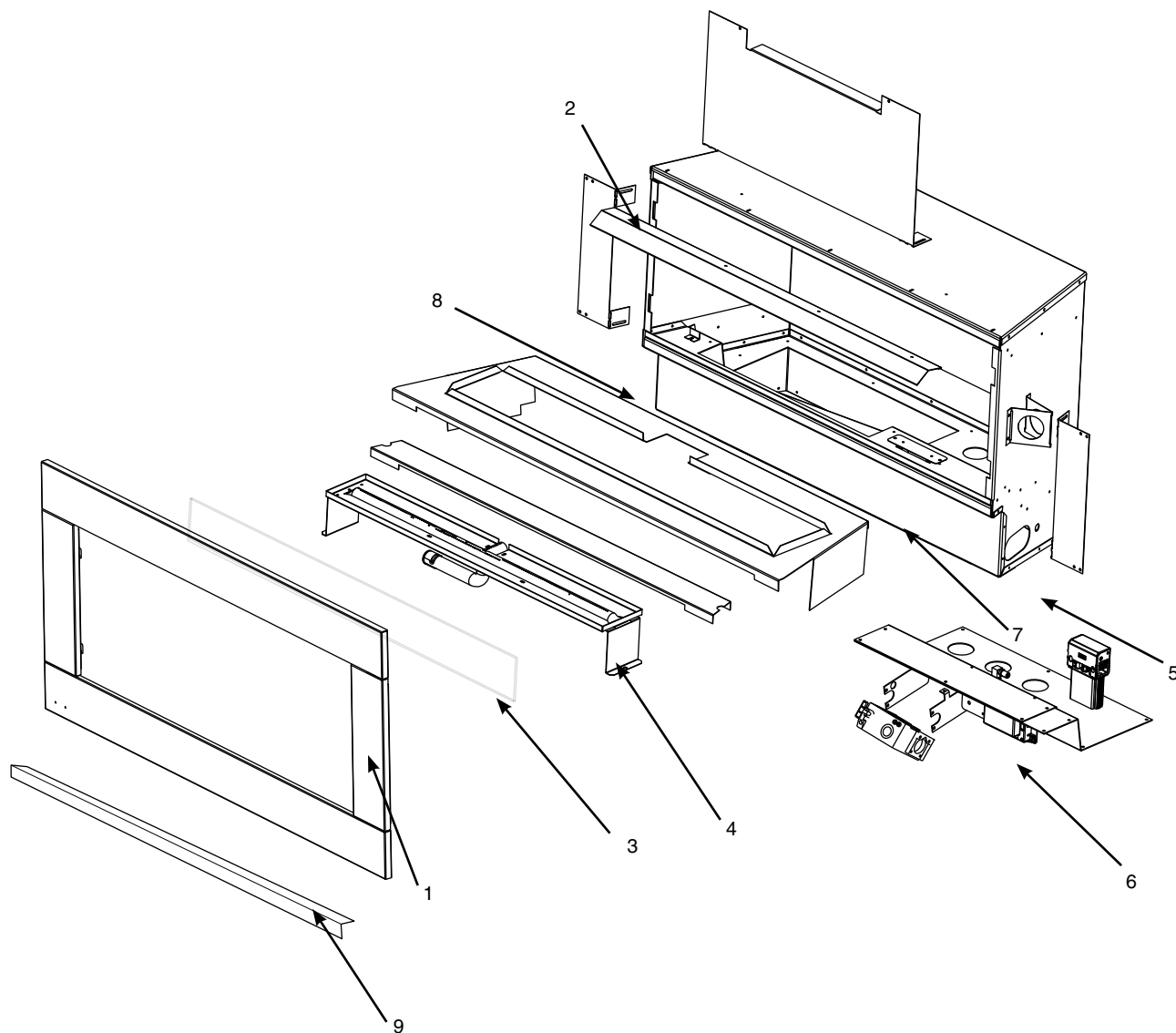

# parts list

## BURNER ASSEMBLY

Part #	Description	Part #	Description
9) 326-525	Burner Assembly NG	904-660	Orifice #29 NG
326-525	Burner Assembly ULPG	904-431	Orifice #47 LPG/ULPG
10) 911-024	Valve NG SIT 880	326-930	Log Set
911-025	Valve LPG/ULPG SIT 880		
11) 326-048	Burner Tray Cover		
12) 911-006	Pilot Assembly - NG		
911-007	Pilot Assembly - LPG/ULPG		
<b>911-037</b>	Flame Sensor		
911-038	Igniter		
910-432	Pilot Tube		

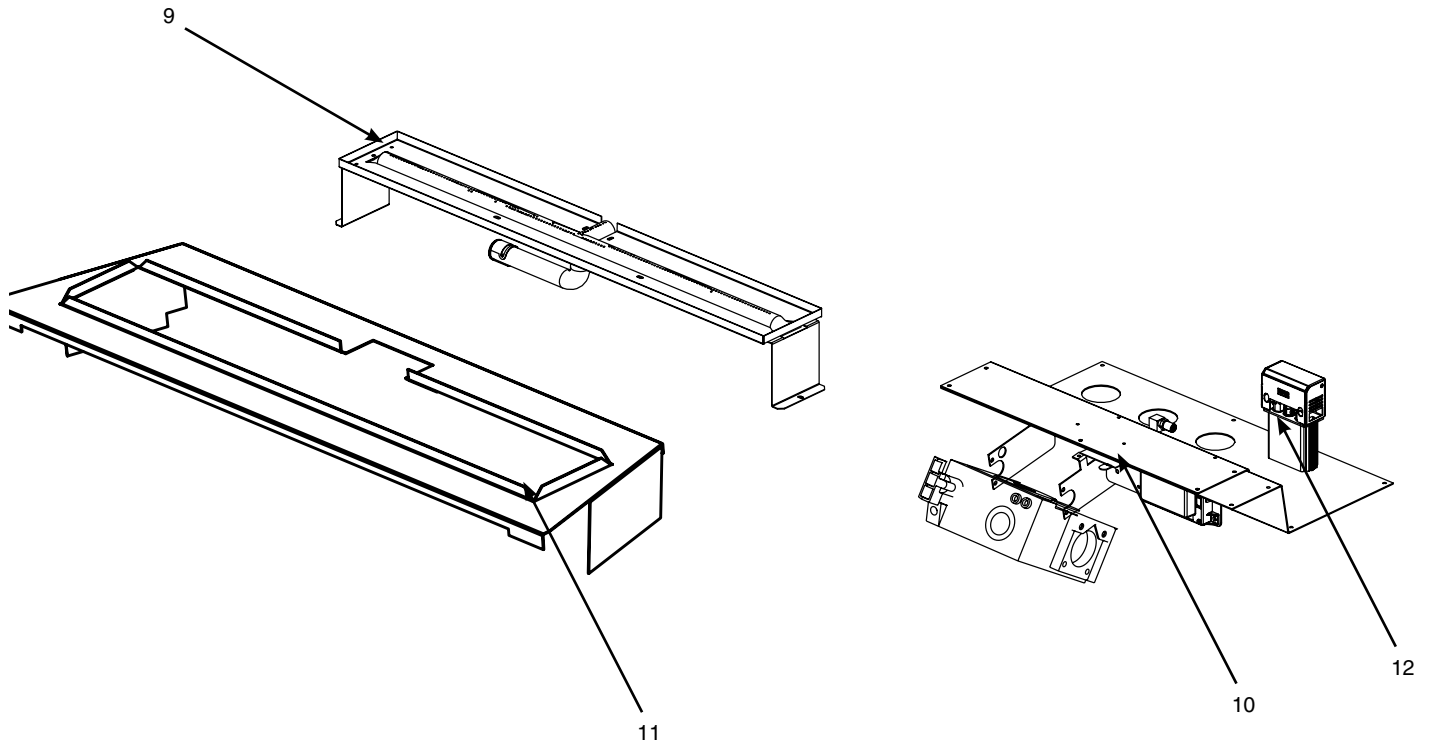



**ACCESSORIES**

Part #	Description
13)	Reflective Stainless Steel Inner Panels
326-021	Rear Panel Stainless
326-022	Left Panel Stainless
326-023	Right Panel Stainless
14)	940-368/P Glass windshield
15)	326-554 Faceplate Brushed Stainless
946-676	Copper Glass Crystals
946-695	Garden Stones

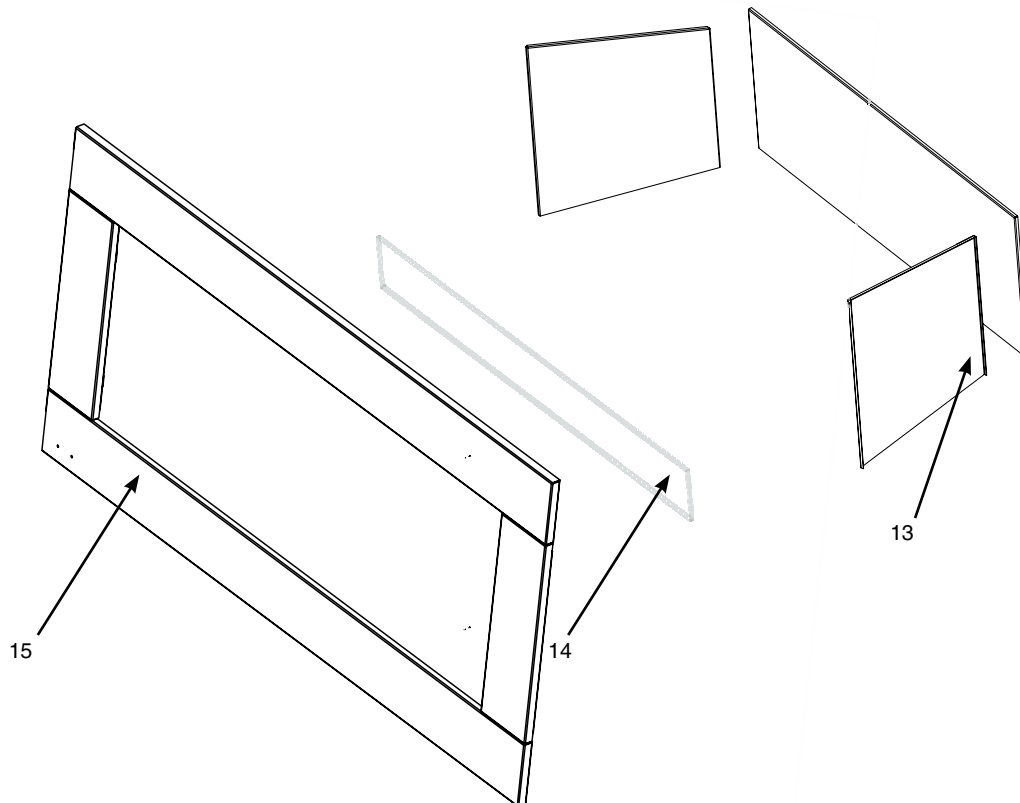

# warranty

## Limited Lifetime Warranty

FPI Fireplace Products International Ltd. (“the manufacturer”) through its wholly owned subsidiary, Fireplace Products Australia Pty Ltd (for Australia and New Zealand customers) and sold under the Regency® brand of fireplace products (collectively referred to herein as “FPI”), extends this Limited Lifetime Warranty to the original purchaser of this appliance provided the product remains in the original place of installation. The items covered by this limited warranty and the period of such coverage is set forth in the table below.

Some conditions apply (see below).

The policy is not transferable, amendable or negotiable under any circumstances.

Indoor Gas Products Warranty Coverage Parts and Labor	Part				Supplier	Labor Coverage
	Lifetime	5 years	2 years	1 year	Warranty	(Years)
Firebox and Heat Exchanger	✓					3
Steel Burner Tube	✓					3
Glass Thermal breakage only	✓					3
All Surrounds/Inlays Finishes		✓				3
Brick Panels/Log sets/Ceramic Burners		✓				3
All Castings		✓				3
Valve assembly and all gas control components (Pilot assembly, flame sensors, Spark Electrode, Pilot Tubing, Orifices, Thermocouple, Thermopile)			✓			2
All Other Electrical components with the exception of WIFI Dongle (Ignition Control Boards, Wiring, Switches, Fans, Fan Control Module, Battery Pack, Remote Control Systems)			✓			1
Enamel Panels			✓			1
Venting/Venting Components			✓			1
All Stainless steel surrounds				✓		1
All Firebox Media (Crystals, Fire beads, Volcanic, Ceramic & Spa Stones)				✓		1
All hardware				✓		1
Mesh/Glass Safety Barriers				✓		1
Accent Light Bulbs				✓		1
Glass (Crazing)				✓		1
WIFI Dongle (Applicable Models)				✓		1

After the original warranty coverage for any of the parts above have expired, any repair and/or replacement parts purchased by the consumer from FPI or through an accredited distributor or dealer will carry a ninety (90) day warranty (valid only with an original copy of the tax invoice). No labor coverage is included with any repair and/or replacement part.

Replacement parts are limited to one per warranty term.

### Conditions:

Warranty protects against defect in manufacture or FPI factory assembled components only, unless herein specified otherwise. This warranty will only apply to those products which are acquired at the time of this warranty being effective. FPI will not be liable for any damage or loss that falls outside the scope of the warranty.

Any part(s) found to be defective during the warranty period as outlined above will be repaired or replaced at FPI's option through an accredited distributor, dealer or pre-approved and assigned agent provided that the defective part is returned to the distributor, dealer or agent for inspection if requested by FPI. Alternatively, FPI may at its own discretion fully discharge all of its obligations under the warranty by refunding the verified purchase price of the product to the original purchaser. The purchase price must be confirmed by an original copy of the tax invoice.

**The authorised selling dealer, or an alternative authorised FPI dealer if pre-approved by FPI, is responsible for all in-field diagnosis and service work related to all warranty claims. This warranty does not cover dealer travel costs for diagnostic or service work. Dealers may charge homeowner for travel and additional time. Check with your selling dealer in advance for any costs to you when arranging a warranty call. FPI is not responsible for results or costs of workmanship of unauthorised FPI dealers or agents in the negligence of their service work. Additional service fees may apply if you are seeking warranty service from a dealer other than the dealer from whom you originally purchased the product.**

At all times FPI reserves the right to inspect reported complaints on location in the field claimed to be defective and determine whether the warranty will apply prior to processing or authorising of any claim. Failure to allow this upon request will void the warranty.

All warranty claims must be submitted by the dealer servicing the claim, including an original copy of the tax invoice (proof of purchase by you). All claims must be complete and provide full details as requested by FPI to receive consideration for evaluation, including proof of maintenance records. Incomplete claims may be rejected. FPI has absolute discretion to assess and determine any warranty claim and may accept or reject a claim as it considers appropriate. Any part or parts of the unit found to be defective will be repaired or replaced at FPI's option, through an accredited distributor or service agent provided that the defective part be returned to the distributor or agent, **Transportation Prepaid**, if requested. **It is the general practice of FPI to charge for larger, higher priced replacement parts and issue credit once the replaced component has been returned to FPI and evaluated for manufacturer defect.**

**If a consumer has a unit installed outside an accredited distributor, dealer or pre-approved service agent's service area, or the closest approved service agent is situated more than thirty (30) kilometres from the installation, FPI is not obliged to arrange warranty repairs or shipping/transportation costs. In these cases, the consumer must arrange warranty service with its selling dealer, and shipping, travel and/or additional labor charges will apply.**

Unit must be installed according to all manufacturers' instructions as per the manual.

All Local and National required codes must be met.

The installer is responsible to ensure the unit is operating as designed at the time of installation.

The original purchaser is responsible for annual maintenance of the unit, as outlined in the owner's manual. As outlined below, the warranty may be voided due to problems caused by lack of maintenance. Annual maintenance records should be retained.

Repair/replacement parts purchased by the consumer from FPI after the original coverage has expired on the unit will carry a 90 day warranty, valid with a receipt only. Any item shown to be defective will be repaired or replaced at our discretion. No labor coverage is included with these parts.

**Exclusions:**

This Limited Lifetime Warranty does not extend to paint, rust or corrosion of any kind due to a lack of maintenance or improper venting, combustion air provision, corrosive chemicals (i.e. chlorine, salt, air, etc.), door or glass gasket.

Malfunction, damage or performance based issues as a result of environmental conditions, location, chemical damages, downdrafts, installation error, installation by an unqualified installer, incorrect chimney components (including but not limited to cap size or type), operator error, abuse, misuse, use of improper fuels, accidents, lack of regular maintenance and upkeep, acts of God, weather related problems from hurricanes, tornados,

## warranty

---

earthquakes, floods, lightning strikes/bolts or acts of terrorism or war, which result in malfunction of the appliance are not covered under the terms of this Limited Lifetime Warranty.

FPI has no obligation to enhance or modify any unit once manufactured (i.e. as products evolve, field modifications or upgrades will not be performed on existing appliances).

Any unit showing signs of neglect or misuse will not be covered under the terms of this warranty policy and may void this warranty. This includes units with rusted or corroded fireboxes which have not been reported as rusted or corroded within three (3) months of installation/purchase. Any alteration to the unit which causes sooting or carboning that results in damage to the exterior fascia or over firing that can cause component or firebox/heat exchanger failure will not be covered by this warranty.

Units which show evidence of being operated while damaged, or with problems known to the purchaser and causing further damages will void this warranty.

Units where the serial no. has been altered, deleted, removed or made illegible will void this warranty.

Minor movement, expansion and contraction of the steel is normal and is not covered under the terms of this warranty.

Freight damages for products or parts are not covered under the terms of the warranty.

Porcelain/Enamel: Absolute perfection is neither guaranteed nor commercially possible. Any chips must be reported and inspected by the authorised selling dealer within three (3) days of installation. Any damage of this type not reported after this time period will be subject to rejection and any related warranty will not apply.

Special Finishes: Expect some changes in color as the product "ages" with constant heating and cooling. The manufacturer warranty does not cover tarnishing, changing colors and/or marks (i.e. finger prints, etc.) after the purchase of the product. Damage from the use of abrasive cleaners is not covered by warranty.

Products made or provided by other manufacturers and used in conjunction with the FPI appliance without prior authorisation from FPI may void this warranty.

**INCORRECT INSTALLATION OR GAS PRESSURE SETTINGS ARE NOT COVERED BY WARRANTY. A SERVICE OR CALLOUT FEE WILL BE CHARGED IN THESE CIRCUMSTANCES.**

---

## **Limitations of Liability:**

### 1. Exclusion of implied terms

The customer may have the benefit of consumer guarantees under the Australian Consumer Law. To the maximum extent permitted by law, all terms, conditions or warranties that would be implied into this Warranty or in connection with the supply of any goods or services by the supplier under law or statute or custom or international conventions are excluded.

### 2. Limitation of liability

(a) To the maximum extent permitted by law and subject to clauses 1 and 3, the supplier's total liability arising out of or in connection with its performance or its obligations pursuant to this Warranty, or arising out of or in connection with the supply of specific goods or services (including pursuant to or for breach of this Warranty, under statute, in equity or for tort, including negligent acts or omissions) is limited as follows: (i) the supplier shall have no liability to the customer for any Consequential Loss; (ii) without limiting the effect of clause 2(a)(i), the supplier's total aggregate liability for Loss, however arising, shall not exceed the GST exclusive aggregate price paid by the customer to the supplier for the specific goods or services that gave rise to the Loss in question.

(b) The limitations and exclusions in this sub-clause do not apply to the extent that any Loss is directly attributable to: (i) the personal injury or death caused by the supplier's default, breach of this Warranty or negligence; or (ii) fraud by the supplier.

(c) Each party must take reasonable steps to mitigate any Loss it suffers or incurs.

### 3. Limitation of liability under Australian Consumer Law Guarantees

(a) To the extent that goods supplied by the supplier are not goods of a kind ordinarily acquired for personal, domestic or household use and the customer is deemed to be a consumer for the purposes of section 64A of the Australian Consumer Law, the customer agrees that the supplier's liability for a failure to comply with a consumer guarantee that the customer may have a benefit under the Australian Consumer Law (other than a guarantee under sections 51 (title), 52 (undisturbed possession) and 53 (undisclosed securities)), is limited to, at the option of the supplier, one or more of the following: (i) replacement of the goods or the supply of equivalent goods; (ii) the repair of the goods; (iii) the payment of the cost of replacing the goods or of acquiring equivalent goods; or (iv) equivalent goods; or (v) the payment of the cost of having the goods repaired.

(b) To the extent that services supplied by the supplier are services other than services of a kind ordinarily acquired for personal, domestic or household use or consumption, the supplier's liability for failure to comply with a consumer guarantee that the customer may have the benefit of is limited to, at the option of the supplier: (i) the supply of the services again; or (ii) the payment of the cost of having the services supplied again.

### 4. Subject to Change

This Limited Warranty is given at the time of sale and purchase of the relevant fireplace product. The terms of this Limited Warranty may be amended from time to time by FPI in accordance with changes to business practices, consumer laws or other legal requirements. The rights and protections granted under the Limited Warranty are those in force in relation to a fireplace product at the time and in the place of sale of that product, and only those terms will be applicable in respect of that product.

### 5. Severability

Any term of this Limited Warranty that is invalid or unenforceable in any jurisdiction is to be read down for the purposes of that jurisdiction, if possible, so as to be valid and enforceable, and is otherwise capable of being severed to the extent of the invalidity or unenforceability, without affecting the remaining provisions of this Limited Warranty or affecting the validity or enforceability of that provision in any other jurisdiction.

### 6. Definitions

For purposes of clauses 1, 2 and 3:

(a) Consequential Loss means loss of expected savings, loss of use, loss of opportunity, loss of profit, loss of revenue, increased financing costs, loss arising from delay, or any consequential, special or indirect loss or damage, whether or not the possibility or potential extent of the loss or damage was known or foreseeable, and whether arising from a claim under indemnity, contract, tort (including negligence), statute or otherwise.

(b) Loss means any expense, cost or damage of any kind and includes Consequential Loss and a fine or penalty imposed by a statutory or other authority.

# warranty

---

## How to Obtain Warranty Service:

Customers should contact the authorised selling dealer to obtain warranty service. In the event the authorised selling dealer is unable to provide warranty service, please contact FPI by mail at the address listed below. Please include your name, address, purchase date, selling dealer, serial #, type of unit, a brief description of the problem, email and telephone contact information, and a copy of your original tax invoice. A representative will contact you to make arrangements for an inspection and/or warranty service. (See below for Western Australia and/or New Zealand)

Please note Fireplace Products Australia Pty Ltd does not provide installation services.

### Fireplace Products Australia Pty Ltd

99 Colmans Road  
Dandenong, VIC  
Australia, 3175  
Phone: +61 3 9799 7277  
Fax: +61 3 9799 7822

To obtain warranty service in Western Australia and/or New Zealand, please contact one of our authorised distributors in those areas:

#### Western Australia:

##### **Air Group Australia**

28-30 Division St.  
Welshpool, WA  
Australia, 6106  
Phone: (08) 9350 2200  
Fax: (08) 9353 4225

#### New Zealand:

##### **Aber Holdings Ltd**

PO Box 10095  
Te Rapa, Hamilton  
New Zealand, 3241  
Freephone: 0800 161 161

## Product Registration and Customer Support:

Thank you for choosing a Regency Fireplace. Regency strives to be a world leader in the design, manufacture, and marketing of hearth products. To provide the best support for your product, we request that you complete a product registration form at <http://www.regency-fire.com.au/Customer-Care/Warranty-Registration.aspx> within ninety (90) days of purchase.



### Product Registration and Customer Support:

Thank you for choosing a Regency Fireplace. Regency strives to be a world leader in the design, manufacture, and marketing of hearth products. To provide the best support for your product, we request that you complete a product registration form found on our Web Site under Customer Care within ninety (90) days of purchase.

For purchases made in **CANADA or the UNITED STATES:**

<http://www.regency-fire.com/Customer-Care/Warranty-Registration.aspx>

For purchases made in **AUSTRALIA:**

<http://www.regency-fire.com.au/Customer-Care/Warranty-Registration.aspx>

You may also complete the warranty registration form below to register your Regency Fireplace Product and mail and/or fax it back to us, and we will register the warranty for you. It is important you provide us with all the information below in order for us to serve you better.

### Warranty Registration Form (or Register online immediately at the above Web Site):

<b>Warranty Details</b>	
Serial Number (required):	
Purchase Date (required) (mm/dd/yyyy):	
<b>Product Details</b>	
Product Model (required):	
<b>Dealer Details</b>	
Dealer Name (required):	
Dealer Address:	
Dealer Phone #:	
Installer:	
Date Installed (mm/dd/yyyy):	
<b>Your Contact Details (required)</b>	
Name:	
Address:	
Phone:	
Email:	

For purchases made in **CANADA:**

**FPI Fireplace Products International Ltd.**  
6988 Venture St.  
Delta, British Columbia  
Canada, V4G 1H4

Phone: 604-946-5155  
Fax: 1-866-393-2806

For purchases made in the **UNITED STATES:**

**Fireplace Products US, Inc.**  
PO Box 2189 PMB 125  
Blaine, WA  
United States, 98231

Phone: 604-946-5155  
Fax: 1-866-393-2806

For purchases made in **AUSTRALIA:**

**Fireplace Products Australia Pty Ltd**  
99 Colmans Road  
Dandenong, VIC  
Australia, 3175

Phone: +61 3 9799 7277  
Fax: +61 3 9799 7822

For fireplace care and tips and answers to most common questions please visit our Customer Care section on our Web Site. Please feel free to contact your selling dealer if you have any questions about your Regency product.













***Installer: Please complete the following information***

**Dealer Name & Address:** \_\_\_\_\_

\_\_\_\_\_

**Installer:** \_\_\_\_\_

**Phone #:** \_\_\_\_\_

**Date Installed:** \_\_\_\_\_

**Serial #:** \_\_\_\_\_