

VISTA

(Model HEHVI AU)

Heat Output	▪	15.2kW av
Efficiency	▪	63% av
Coverage	▪	up to 180m ²
Emissions	▪	1.5 grams/kg

Cast in their own foundry the Vista from Hergom has a contemporary design incorporating curved lines that offer a rigid contrast to the fluidity of the flames, visible through the large glass front.

Providing a constant, gentle warmth due to the heat retention properties of its robust cast iron, the Vista continues to emit heat even after the fire has died down. Even the internal plates of the combustion chamber are made of cast iron.

The smallest details are designed to delight - like the polished stainless steel handle, which is a dramatic contrast to the rich dark grey of the cast iron.

In the more than fifty years of professional experience, Hergom has perfected its production process, controlling first-hand the design, casting and manufacturing of each of its products.

Today they are one of the leading companies in the heating sector worldwide, with five manufacturing and operations points in Europe and America.



Dimensions

Features

Hearth depth inc 300mm in front. Thickness: Equal to 6mm floor protector [compressed board or equivalent]	Width	Depth	Thickness
No shielding	800	1660	6
With Skamol Enclosure Board 25mm thick skamol board wall protector against the combustible rear wall must be 1800mm high x 1570 long and shall extend 520mm past either side of the appliance. The Skamol board on the side wall shall be 1800mm high and 1450mm long and must extend 520mm in front of the fuel	800	1210	6
With Skamol Enclosure Board 25mm thick Skamol boards with a 25mm air gap from the combustible surface, the skamol boards should extend to a minimum height of 1800mm from the floor protector. The Skamol board on the rear wall must extend 520mm past either side of the appliance. The Skamol board on the side wall shall extend 520mm in front of the fuel loading door. The shielding must be vented at top and bottom to allow flow of air through the air gap.	800	860	6

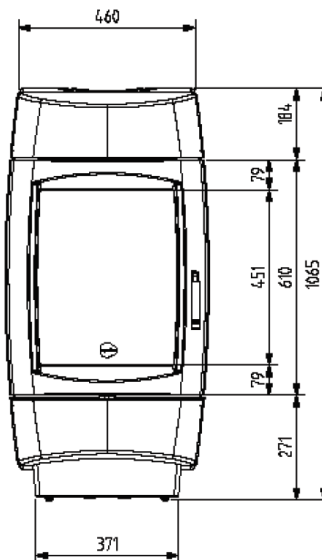

STANDARD FEATURES

- Manufactured almost entirely from cast iron
- Combustion chamber with high-strength cast iron liners
- Superior air wash cleaning system. Air currents sweep the inner part of the glass, keeping it free of dust and particles for unparallelled fire viewing
- Primary air control valve
- Removable ash tray for a clean convenient disposal of ashes
- Vertical smoke exit through the top
- Weight : 205kilos
- Maximum log width : 500mm
- Flue Spigot Size : Ø 150mm 6inch
- Internal Firebox : 510[w] x 303[d] x 490[h]
- Viewing Area : 371[w] x 451[h]
- Warranty : Limited 2 years manufactures

Information supplied is to assist you in your choice of a suitable fire. It is not intended to be all the information required to install the fire and does not replace the installation manual which provides more detailed information. In the interest of product development Hergom reserves the right to change specifications without prior notice.

All measurements are in millimetres unless otherwise stated.

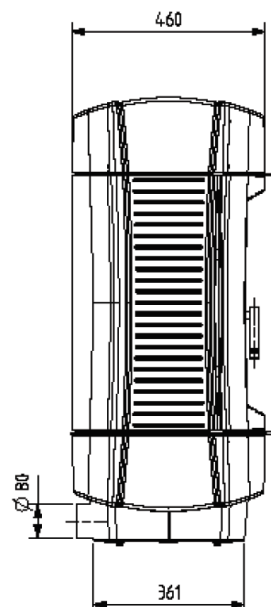
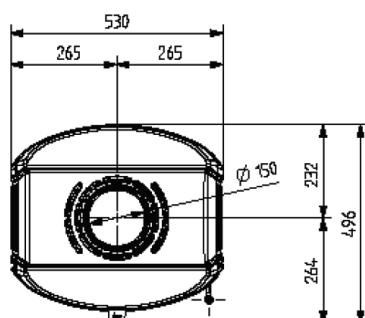

VISTA

(Model HEHVI AU)



Clearances

No Shielding

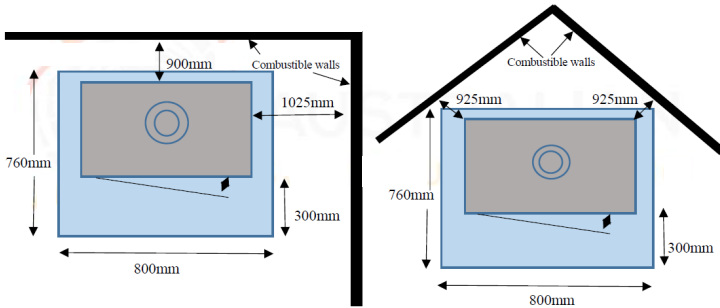

Skamol

25mm thick skamol board wall protector against the combustibile rear wall must be 1800mm high x 1570 long and shall extend 520mm past either side of the appliance. The Skamol board on the side wall shall be 1800mm high and 1450mm long and must extend 520mm in front of the fuel

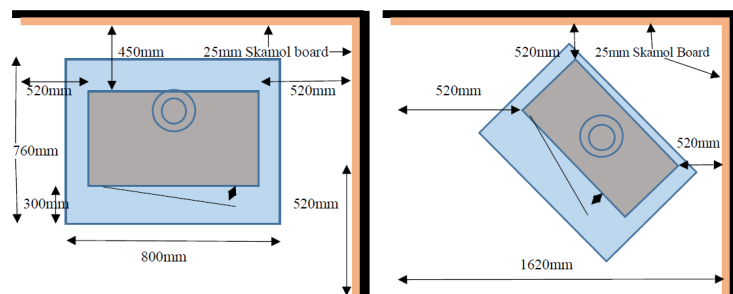

Skamol

25mm thick Skamol boards with a 25mm air gap from the combustibile surface, the skamol boards should extend to a minimum height of 1800mm from the floor protector. The Skamol board on the rear wall must extend 520mm past either side of the appliance. The Skamol board on the side wall shall extend 520mm in front of the fuel loading door. The shielding must be vented at top and bottom to allow flow of air through the air gap.

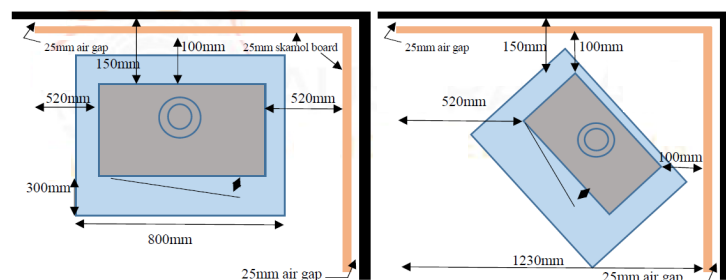

Flue Shield Configuration

Flue Shield Configuration	Rear	Side	Front	Corner
No shielding	900	1025	300	925
With Skamol Enclosure Board 25mm thick skamol board wall protector against the combustibile rear wall must be 1800mm high x 1570 long and shall extend 520mm past either side of the appliance. The Skamol board on the side wall shall be 1800mm high and 1450mm long and must extend 520mm in front of the fuel	450	520	300	520
With Skamol Enclosure Board 25mm thick Skamol boards with a 25mm air gap from the combustibile surface, the skamol boards should extend to a minimum height of 1800mm from the floor protector. The Skamol board on the rear wall must extend 520mm past either side of the appliance. The Skamol board on the side wall shall extend 520mm in front of the fuel loading door. The shielding must be vented at top and bottom to allow flow of air through the air gap.	100	520	300	100

CLEARANCES BASED ON INSTALLATION 6" TRIPLE SKIN FLUE KIT WITH 8" SOLID CASINGSOLID DECORATIVE FLUE SHIELD