

IMPORTANT

It is the responsibility of the installer to ensure that the installation of this appliance complies with AS/NZS 2918:2001



Supplied: Ethos freestanding fire
Flue kit: 3 x 1200 130mm SS flue
1 x 600 130mm SS flue
2 x 200 x 1200 liners (black)
1 x 200 x 1200 liner (galv)
1 x Revolving cowl & cone
1 x Ceiling plate (black)

Not included in kit: Flashing
Hearth / Floor protector
Screws / Rivets
Dynabolts
Fire cement
Mounting rails

Flue kit: **Ethos wood fires must be fitted with the Ethos factory flue kit** as this has been specifically designed to achieve optimum performance of the unit. It must be a minimum of 4.2 mtrs.

note: It is essential that the 130mm stainless steel flue is well sealed & riveted it must also be securely fitted & sealed into the exhaust spigot of the fire using stainless steel rivets or screws.

Shielding: The Ethos Genesis / Aquos / Phoenix wood fires do not require additional shielding, however reduced clearances may be obtained using approved heat resistant material.
(ref: AS/NZS 2918: 2001)

Seismic restraint: Use 2 x 6mm dynabolts or similar, two holes are provided in the rear of the firebox pedestal or feet for this purpose.

Floor protector: The floor protector must be an approved heat resistant material.

WARNING: THE APPLIANCE AND FLUE SYSTEM SHALL BE INSTALLED IN ACCORDANCE WITH AS/NZS 2918: 2001 AND THE APPROPRIATE REQUIREMENTS OF THE RELEVANT BUILDING CODE OR CODES.



WARNING: APPLIANCES INSTALLED IN ACCORDANCE WITH THIS STANDARD SHALL COMPLY WITH THE REQUIREMENTS OF AS/NZS 4013 WHERE REQUIRED BY THE REGULATORY AUTHORITY, I.E. THE APPLIANCE SHALL BE IDENTIFIABLE BY A COMPLIANCE PLATE WITH THE MARKING "TESTED TO AS/NZS 4013 "



ANY MODIFICATION OF THE APPLIANCE THAT HAS NOT BEEN APPROVED IN WRITING FROM THE TESTING AUTHORITY IS CONSIDERED TO BE IN BREACH OF THE APPROVAL GRANTED FOR COMPLIANCE WITH AS/NZS 4013.



CAUTION: MIXING OF APPLIANCE OR FLUE SYSTEM COMPONENTS FROM DIFFERENT SOURCES OR MODIFYING THE DIMENSIONAL SPECIFICATION OF COMPONENTS MAY RESULT IN HAZARDOUS CONDITIONS. WHERE SUCH ACTION IS CONSIDERED, THE MANUFACTURER SHOULD BE CONSULTED IN THE FIRST INSTANCE.



CAUTION: CRACKED AND BROKEN COMPONENTS, e.g. GLASS PANELS OR FIREBRICKS, MAY RENDER THE INSTALLATION UNSAFE.



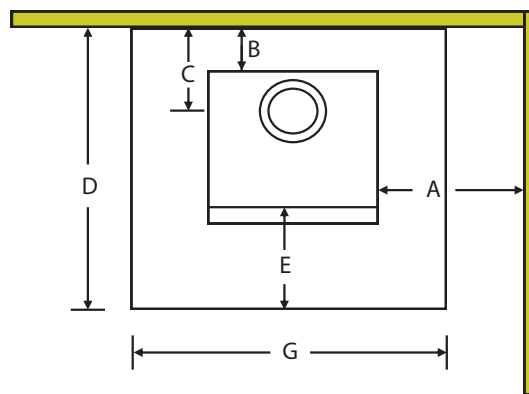
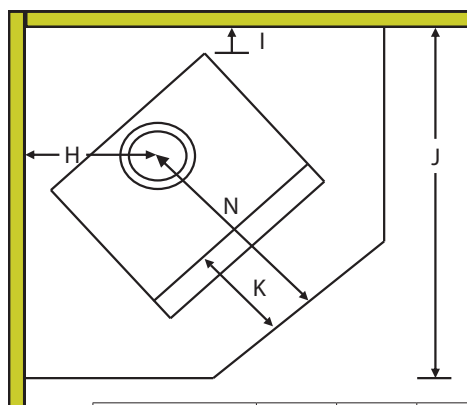
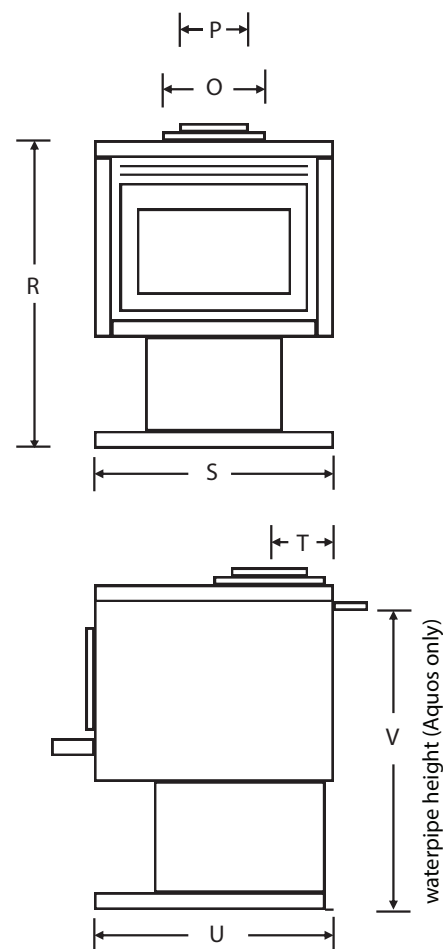
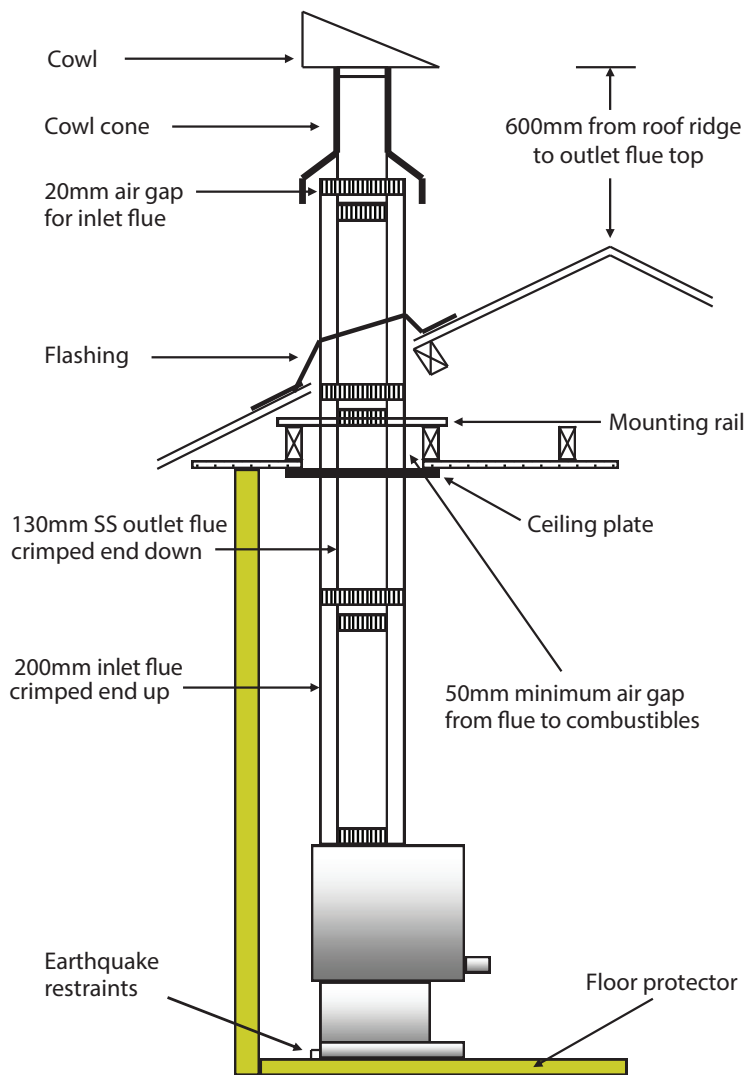

all clearances mm	A	B	C	D	E	G	H	I	J	K	N
No flue shield	310	170	300	955	300	800	320	38	1000	300	650
With flue shield	310	85	210	870	300	800	301	19	1000	300	650

all dims mm	O	P	R	S	T	U	V
Genesis	200	130	740	540	130	485	-
Aquos	200	130	740	540	130	485	670
Phoenix	200	130	670	540	130	485	-



IMPORTANT: It is the responsibility of the installer to ensure that the installation of this appliance complies with AS/NZS 2918:2001. The above installation diagrams are provided as a guide only.

Australia

Capisco Aust Pty Ltd
 2/281 Pacific Highway
 North Sydney, NSW 2060
 Phone (02) 8310 7304
 www.capisco.com.au

New Zealand

Capisco Ltd
 PO Box 938, Whangaparaoa
 Auckland 0930
 Phone (09) 947 5166
 www.capisco.co.nz

Notes/Installer/Dealer Details